

4535 Average Temperature Converter

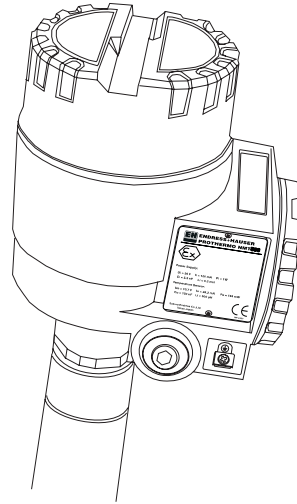

Installation and Operations Manual

For Software Version 5.x



www.varec.com

Copyright

All rights reserved. Printed in the United States of America. Except as permitted under the United States Copyright Act of 1976, no part of this publication may be reproduced, stored in a retrieval system or transmitted in any form or by any means— electronic, mechanical, photocopying, recording or otherwise— without the prior written permission of the Publisher:

Varec, Inc.
5834 Peachtree Corners East
Norcross (Atlanta) GA 30096
USA

Trademarks acknowledged

Varec, Inc. recognizes all other trademarks. Trademarks of other products mentioned in this document are held by the companies producing them.

Varec® is a registered trademark of Varec, Inc., a wholly-owned subsidiary of Science Applications International Corporation

Disclaimer of Warranties

The contract between the Seller and the Buyer states the entire obligation of the Seller. The contents of this document shall not become part of or modify any prior or existing agreement, commitment or relationship between the Seller and Buyer. There are no express or implied warranties set out in this document. The only warranties that apply are those in the existing contract between the Seller and Buyer.

Varec, Inc. products have not been tested by Varec, Inc. under all possible operational conditions, and Varec, Inc. may not have all the data relative to your application. The information in this document is not all inclusive and does not and cannot take into account all unique situations. Consequently, the user should review this product literature in view of his/her application. If you have any further questions, please contact Varec, Inc. for assistance.

Limitations of Seller's Liability

In the event that a court holds that this document created some new warranties, Seller's liability shall be limited to repair or replacement under the standard warranty clause. In no case shall the Seller's liability exceed that stated as Limitations of Remedy in the contract between the Seller and Buyer.

Terms of Use

The information provided in this document is provided "as is" without warranty of any kind. Varec, Inc. disclaim all warranties, either express or implied, including the warranties of merchantability and fitness for a particular purpose. In no event shall Varec, Inc. or its suppliers be liable for any damages whatsoever including direct, indirect, incidental, consequential, loss of business profits or special damages, even if Varec, Inc. or its suppliers have been advised of the possibility of such damages.

Use of parts that are not manufactured or supplied by Varec, Inc. voids any Varec, Inc. warranty and relieves Varec, Inc. of any obligation to service the product under warranty. Varec, Inc. recommends the use of only Varec, Inc. manufactured or supplied parts to maintain or service Varec, Inc. products.

Use of parts that are not manufactured or supplied by Varec, Inc. invalidates the agency approval for this product.

Safety Precaution Definitions

Caution! Damage to equipment may result if this precaution is disregarded.

Warning! Direct injury to personnel or damage to equipment which can cause injury to personnel may result if this precaution is not followed.

Safety Precautions

Read and understand this instruction manual before installing, operating or performing maintenance on the Varec 4535 Average Temperature Transmitter/Probe. Follow all precautions and warning noted herein when installing, operating or performing maintenance on this equipment.

Contents

1	Introduction and Safety instructions	1
1.1	Designated use	1
1.2	Product Requirements	1
1.2.1	Power source	1
1.2.2	Use in hazardous areas	1
1.2.3	External connection	1
1.3	Installation, commissioning and operation	1
1.4	Operational safety	2
1.4.1	Proper use	2
1.4.2	Protection from line noise	2
1.4.3	On safety and improper use	2
1.5	Return	2
1.6	Safety conventions and symbols	3
2	Identification	5
2.1	Device Designation	5
2.1.1	Nameplate	5
2.1.2	Specifications	6
3	Installation	9
3.1	Dimensions	9
3.2	Mounting	9
3.2.1	Mounting on a Fixed Roof Tank	10
3.2.2	Mounting on a Floating Roof Tank	16
4	Wiring	21
4.1	Required Cabled Ground and Cable	21
4.2	Wiring Procedure	21
5	Operation	23
5.1	Operating on Matrix While Connected to the 6000 Series Servo Tank Gauge	23
5.1.1	Display and Operating Elements	23
5.1.2	Functions of the Operating Elements	24
5.1.3	HOME position	25
5.1.4	Access Code	26
5.1.5	Description of the Programming Matrix	27
5.2	Setting the Matrix on a 6000 Series Servo Tank Gauge	28
5.3	Programming Matrix	29
5.3.1	Matrix G0 Static matrix	30
5.3.2	Matrix G4 Temperature matrix (Dynamic)	31

- 5.3.3 Matrix G7 Adjust Sensor matrix (Dynamic) 32
- 5.4 Description of the Programming Matrix. 33

- A Order Structure**. 39

- B Temperature Ranges and Element Tolerances** 41

- C Error Codes** 43
- C.1 Short Circuit or Break 43
- C.2 Communication Error 43
- C.3 Error and Status Messages 43

1 Introduction and Safety instructions

1.1 Designated use

The 4535 Average Temperature Converter (ATC) is a combined average temperature signal converter and element probe used on bulk storage tanks for inventory control and custody transfer applications. The 4535 ATC can be combined with various HART compatible devices and tank sensors, such as Varec's 6000 Series Servo Tank Gauge, 7200 or 7500 Series Radar Tank Gauge and 4590 Tank Side Monitor (TSM).

The 4535 Average Temperature Converter measures the average product temperature and converts the input to HART compatible output. The temperature data is used for the calculation of the volume correction factor (VCF) and the Net Standard Volume (lower case) required for accurate inventory measurement.

Caution! Before opening the cover of the 4535 ATC for maintenance, switch off the power supply of the 6000 Series Servo Tank Gauge or the 4590 TSM. Either of described instruments are the host gauge for supplying DC voltage on the HART line.

1.2 Product Requirements

1.2.1 Power source

Check the voltage of the power supply before connecting it to the product. It should be the exact voltage required for proper operation of the product.

1.2.2 Use in hazardous areas

When using the product in a first or second-class hazard location (Zone 1 or Zone 2) be sure to use an intrinsically safe or pressure and explosion-proof apparatus. Take the most care during the installation, wiring, and piping of such an apparatus to ensure the safety of the system. For safety reasons, maintenance or repairs on the product while it is being used with such an apparatus should only be performed by qualified personnel.

1.2.3 External connection

When an external connection is required, the product should be protectively grounded before it is connected to a measurement object or an external control circuit.

1.3 Installation, commissioning and operation

- Mounting electrical installation, start-up and maintenance of the instrument may only be carried out by trained personnel authorized by the operator of the facility.
- Personnel must absolutely and without fail read and understand this manual before carrying out its instructions.
- The instrument may only be operated by personnel who are authorized and trained by the operator of the facility. All instructions in this Manual are to be observed without fail.
- The installer has to make sure that the measuring system is correctly wired according to the wiring diagrams. The measuring system is to be grounded.

- Please observe all provisions valid for your country and pertaining to the opening and repairing of electrical devices.

1.4 Operational safety

1.4.1 Proper use

Warning! The 4535 ATC temperature elements assume that users gauge temperature inside the liquid tanks. Use for purposes other than originally intended may cause failure. Failure may occur if the elements are positioned incorrectly or as a result of improper operation. Carefully read this instruction manual before attempting to use the elements.

Warning! Before opening the cover of the 4535 ATC for maintenance, switch off the power supply of the 6000 Series Servo Tank Gauge. The 4535 ATC is supplied with electric power from the 6000 Series Servo Tank Gauge.

1.4.2 Protection from line noise

Caution! The following precautions are required to rule out any malfunction by line noise.

- Use a more than 24 AWG screened twisted pair or steel armored wire for the connection between the 4535 ATC and the 6000 Series Servo Tank Gauge or the 4590 TSM.
- If you use an unscreened wire, then equip it with a conduit pipe.
- Connect the cable screen to the frame ground.

1.4.3 On safety and improper use

Follow the safeguards presented in this manual when using this product. This is important for ensuring the safe operation of the system to be controlled by the product. If the user does not follow these instructions properly, we cannot guarantee the safety of the system.

1.5 Return

The following procedure must be carried out before a transmitter is sent to Varec for repair.

- Always enclose a duly completed "Hazardous Substance Data sheet" form. Only then can Varec transport, examine and repair a returned device.
- Enclose special handling instructions if necessary, for example a safety data sheet as per EN /155 / EEC.
- Remove all residue which may be present. Pay special attention to the gasket grooves and crevices where fluid may be present. This is especially if the fluid is dangerous to health, e.g. corrosive, poisonous, carcinogenic, radioactive, etc.

A copy of the "Hazardous Substance Data sheet" is included at the end of this operating manual.





Caution! No instrument should be sent back for repair without all dangerous material being completely removed first, e.g. in scratches or diffused through plastic.



Caution! Incomplete cleaning of the instrument may result in waste disposal or cause harm to personnel (burns, etc.). Any costs arising from this will be charged to the operator of the instruments.

1.6 Safety conventions and symbols

In order to highlight safety-relevant or alternative operating procedures in the manual, the following conventions have been used, each indicated by a corresponding symbol in the margin.

Symbol	Meaning
Warning!	A warning highlights actions or procedures which, if not performed correctly, will lead to personal injury, a safety hazard or destruction of the instrument.
Caution!	Caution highlights actions or procedures which, if not performed correctly, may lead to personal injury or incorrect functioning of the instruments.
Note!	A note highlights actions or procedures which, if not performed correctly, may indirectly affect operation or may lead to an instrument response which is not planned.

	<p>Device certified for use in explosion hazardous area</p> <p>If the 7200 or 7500 Series Radar Tank Gauge has this symbol embossed on its name plate it can be installed in an explosion hazardous area.</p>
	<p>Explosion hazardous area</p> <p>Symbol used in drawings to indicate explosion hazardous area.</p> <ul style="list-style-type: none"> – Devices located in and wiring entering areas with the designation "explosion hazardous areas" must conform with the stated type of protection.
	<p>Safe area (non-explosion hazardous area)</p> <p>Symbol used in drawings to indicate, if necessary, non-explosion hazardous areas.</p> <ul style="list-style-type: none"> – Devices located in safe areas still require a certificate if their outputs run into explosion hazardous areas.
	<p>Direct voltage</p> <p>A terminal to which or from which a direct current or voltage may be applied or supplied</p>
	<p>Alternating voltage</p> <p>A terminal to which or from which an alternating (sine-wave) current or voltage may be applied or supplied</p>

	<p>Grounded terminal</p> <p>A grounded terminal, which as far as the operator is concerned, is already grounded by means of an earth grounding system.</p>
	<p>Protective grounded (earth) terminal</p> <p>A terminal which must be connected to earth ground prior to making any other connection to the equipment.</p>
	<p>Equipotential connection (earth bonding)</p> <p>A connection made to the plant grounding system which may be of type e.g. neutral star or equipotential line according to national or company practice</p>

2 Identification

2.1 Device Designation

2.1.1 Nameplate

The following technical data are given on the instrument nameplate:

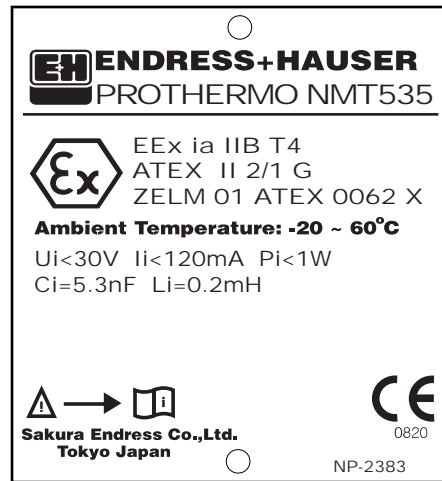

4535 ATC Nameplate



NMT536 Nameplate

2.1.2 Specifications

measuring element	Platinum (Pt.100), Class A element (standard type) PUB 751 1983 and / or JIS 1604 0 1989
Accuracy of element	$\pm(0.15+0.002 t)$ °C, $\pm(0.3+0.004 t)$ °F or better
Accuracy of conversion	$\pm 0.25^{\circ}\text{C}$ ($\pm 0.5^{\circ}\text{F}$) or better
Total Accuracy	$\pm\{0.25+(0.15+0.002 t)\}$ °C, $\pm\{0.5+(0.3+0.004 t)\}$ °F
Measuring range	20... + 100 °C, -4... +212 °F (standard) 50... + 200 °C, -58... +392 °F (wide range) 18... + 80 °C, 0... +176 °F (PTB W&B)..... pending
Number of elements	2...16 point,
Flange	JIS 10K 50A RF ANSI 150 lbs. 2" RF JPI 150 lbe. 2" RF DIN DN50 PN10RF Others (optional)
Output	Multidrop HART Protocol Polling address: 02 for connecting to 6000 Series Servo Tank Gauge. Polling address: 01-0F without 6000 Series Servo Tank Gauge
Materials	Flexible tube (Inner tube): Stainless steel 316 grade Flexible tube (Outer tube): Stainless steel 304 grade Housing: Aluminium diecast ¾" threaded Flange: Mild steel (standard), SS 304 / 316 (optional)
Power supply	DC 16-30V (6000 Series Servo Tank Gauge Supplies DC24V)
Cable entry	G (PF) ½ NPT ½ PG16 M20
Ambient temperature	-20... +60 °C, -4...+140 °F Converter (housing)
Explosion proof (4535 ATC)	Ex d IIB T4, TIIS EEx ia IIB T4 and T2 ATEX Is class1,Div 1, Gp.CD, FM Class 1, Div.1,Gp CD, CSA(Exi)...pending
Explosion proof (NMT536)	EEx d IIB T6 CENELEC

Element position (standard)	Lowest 100mm (3.9") above bottom of flexible tube Highest 1000 mm (39.4") below flange surface
Flexible tube of cable bottom	400 mm from tank bottom

3 Installation

3.1 Dimensions

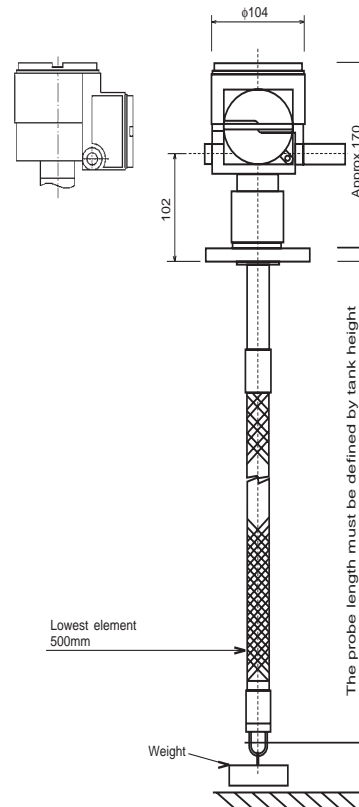

Figure 3-1: Dimensions

3.2 Mounting

1. The flexible tube or cable length of the 4535 ATC is defined for the customer's specifications. Before mounting check them as follows;
 - The tag number (if available) on the body of the 4535 ATC
 - The length of the flexible tube or cable
 - The number of measuring points
 - The intervals between measuring points
2. Mount the 4535 ATC at least 500 mm away from the tank shell. This will insure that the measurement is not influenced by changes of the ambient temperature.
3. 3)The procedure for mounting the 4535 ATC on a tank depends on the type of the tank. Here we shall explain the procedures for a fixed roof tank and for a floating roof tank. In any case, the flexible tube head is mounted on the tank top. The mounting nozzle should have a diameter of 2" (standard).

Warning! 4535 ATC is not design to use in over atmospheric pressure. Please install the 4535 ATC with pressure tight still well for the safety.

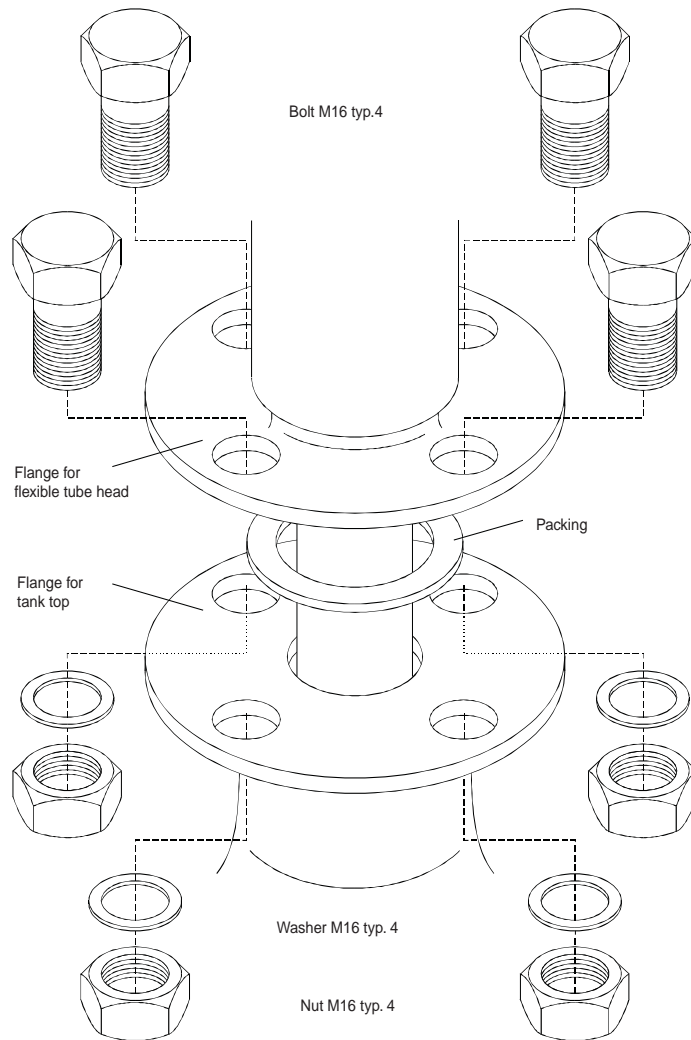

Figure 3-2: Mounting of the flexible tube head on the tank top

3.2.1 Mounting on a Fixed Roof Tank

There are three methods of mounting the 4535 Average Temperature Converter on a fixed roof tank:

- Top anchor method
- Stilling well method
- Anchor weight method

3.2.1.1 Top Anchor Method

The flexible tube is stabilized by a wire hook and a top anchor.

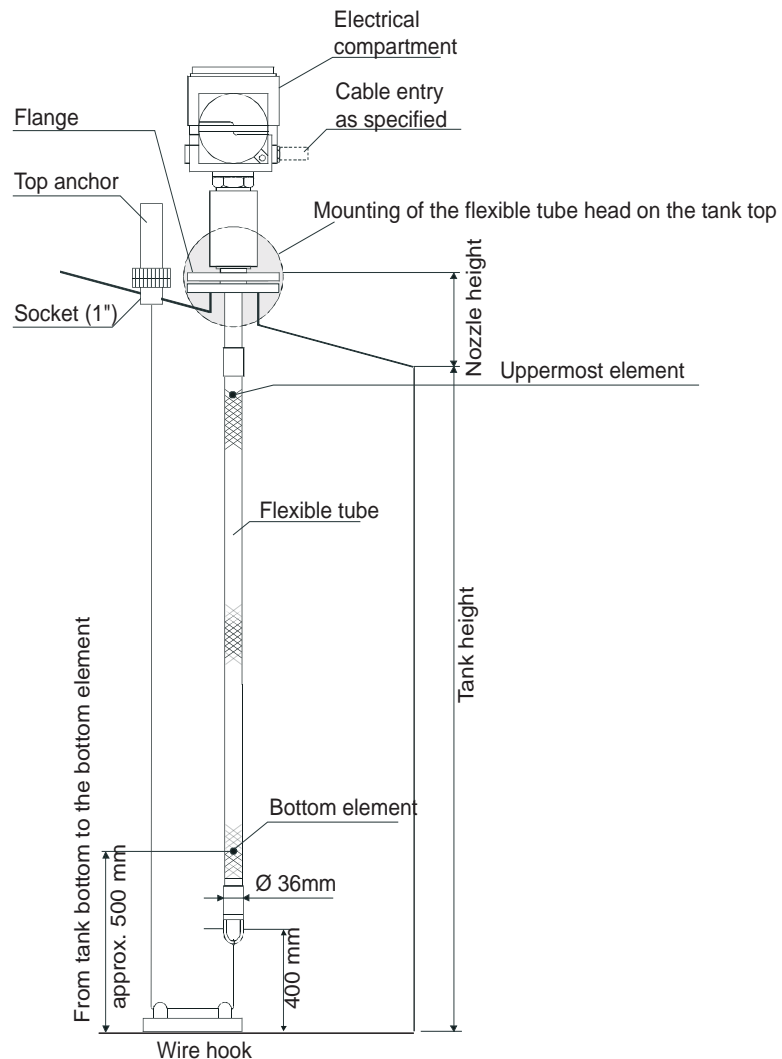

Figure 3-3: Mounting on a fixed roof tank by the top anchor method

Note! If the tank bottom is equipped with a heating coil, then increase the distance between flexible tube and bottom accordingly.

The installation procedure comprises the following steps:

1. Install a gasket and lower the flexible tube into the nozzle on the tank top.

Caution! The flexible tube must be lowered carefully to prevent damage by touching the nozzle.

2. Rotate the 4535 ATC such that you can most conveniently set the cabling.
3. Straighten the tensioning wire, fix its end provisionally to the anchor, and lower the wire.
4. Draw the tensioning wire through the wire hook on the tank bottom.

5. Wind the tensioning wire twice round the hitch, tighten it, and wrap a commercial wire round it.

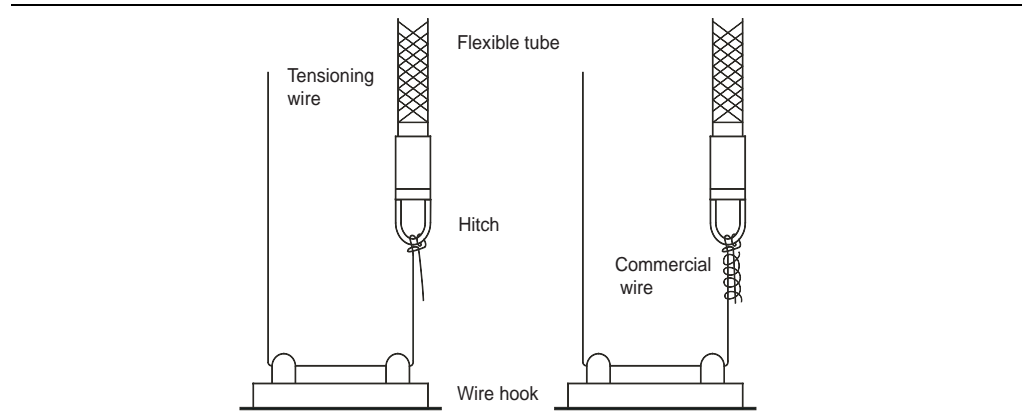
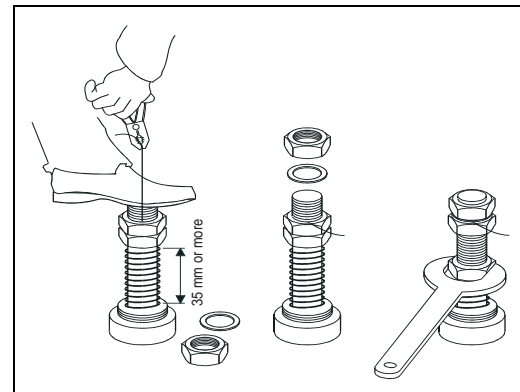

Figure 3-4: Setting of the tensioning wire on the tank bottom

6. Fix the mounting flange of the Prothemo to the nozzle on the tank top by bolts
7. Draw the end of the tensioning wire as much as possible by hand and foot.

Figure 3-5: Fixing of the tensioning wire to the top anchor

8. Bend the wire and fix it by the tightening nut
9. Cut the excess wire.
10. Scw the bolt and press down the spring of the top anchor by 35mm or more.
11. Cover the top anchor



3.2.1.2 Stilling Well Method

The flexible tube is inserted into a stilling well a diameter of 2" or more.

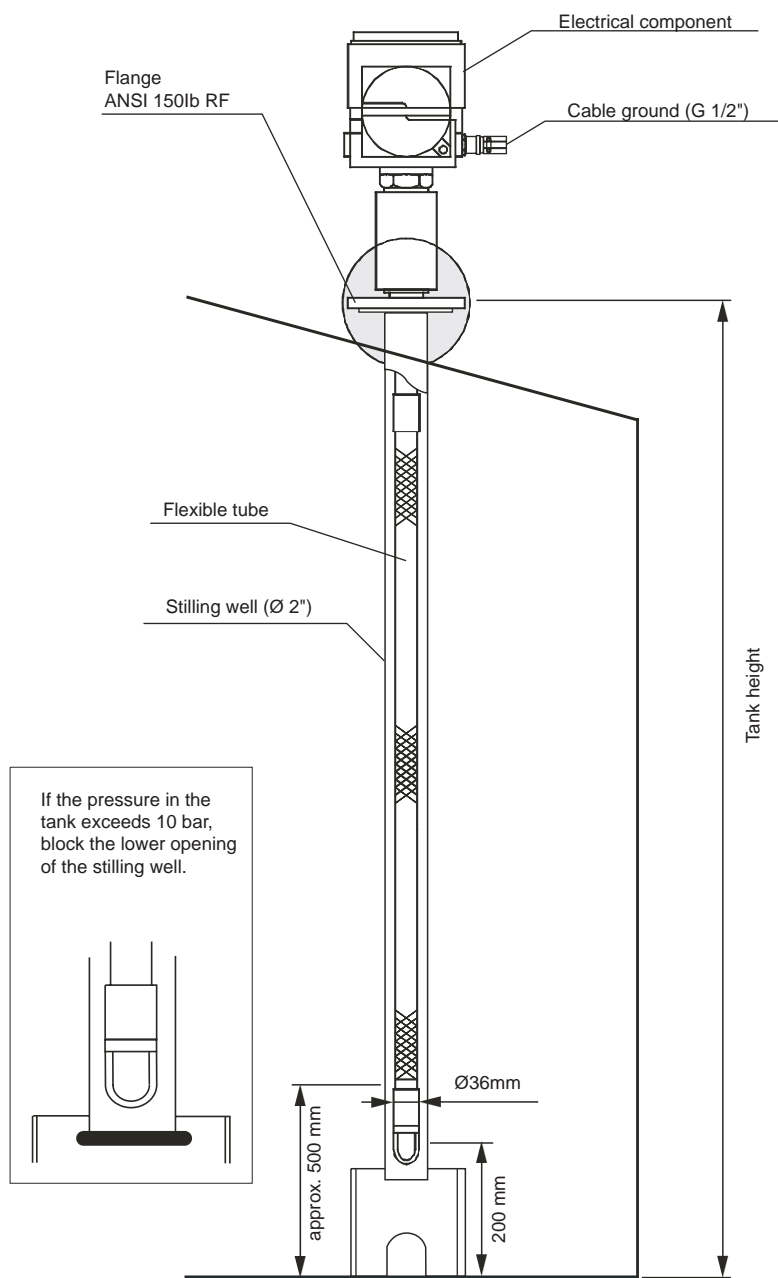

Figure 3-6: Mounting on a fixed roof tank by the stilling well method

Note! If the tank bottom is equipped with a heating coil, then increase the distance between flexible tube and bottom accordingly.

The installation procedure comprises the following steps:

1. Install a gasket and lower the flexible tube into the inlet of the stilling well.

Caution! The flexible tube must be lowered carefully to prevent damage by touching the nozzle.

2. Rotate the 4535 ATC such that you can most conveniently set the cabling.
3. Fix the mounting flange of the 4535 ATC to the nozzle on the tank top by a bolt.

3.2.1.3 Anchor Weight Method

The flexible tube is stabilized by an anchor weight.

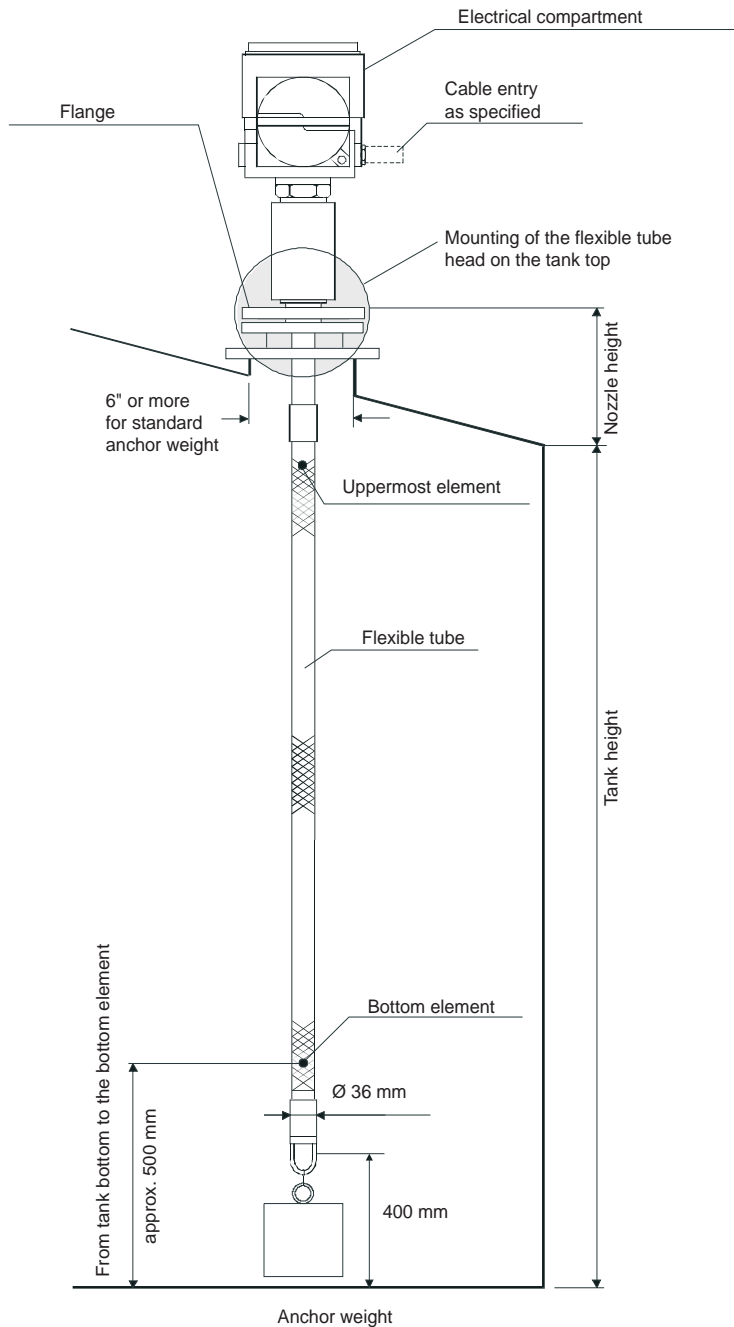

Figure 3-7: Mounting on a fixed roof tank by the anchor weight method

Note! If the tank bottom is equipped with a heating coil, then increase the distance between flexible tube and bottom accordingly

The installation procedure comprises the following steps:

1. Install a gasket and lower the flexible tube into the nozzle on the tank top.

Caution! The flexible tube must be lowered carefully to prevent damage by touching the nozzle.

2. Rotate the 4535 Average Temperature Converter such that you can most conveniently set cabling.
3. Tighten the tensioning wire between the lower end of the flexible tube and the anchor weight.
4. Wind the tensioning wire twice round each of the hitches and the anchor weight.

Note! Make sure that the anchor weight is hanging steadily about 10...15mm above the tank bottom.

The exact distance depends on the tank height and the type of liquid.

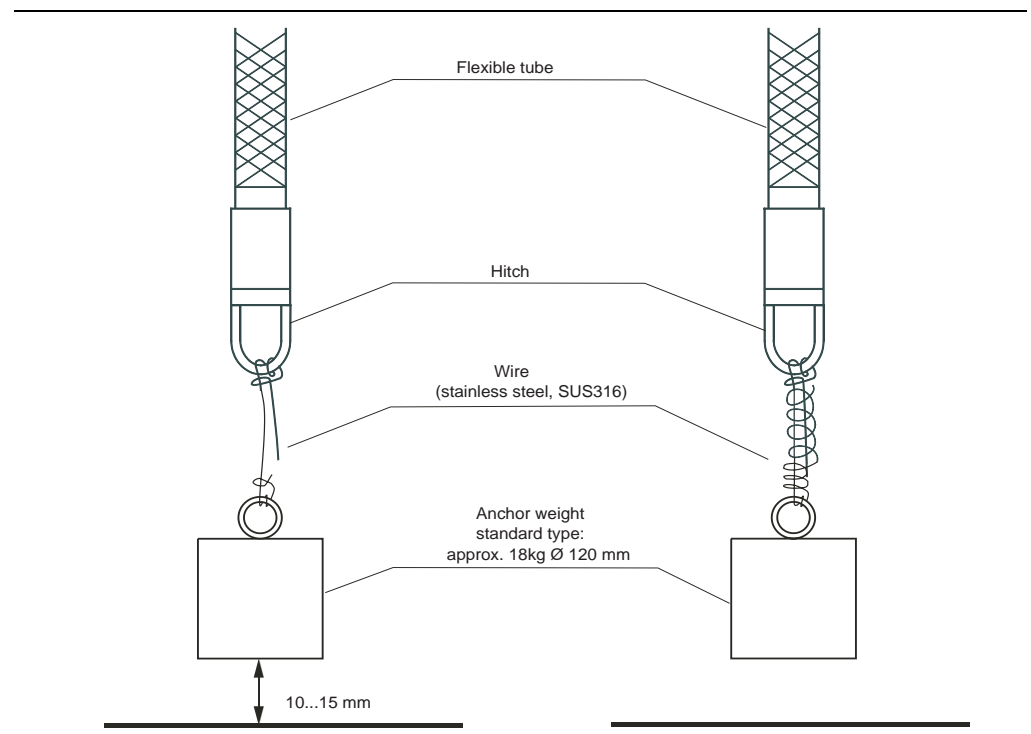

Figure 3-8: Setting of the anchor weight above the tank bottom

5. Fix the mounting flange of the 4535 ATC to the nozzle on the tank top by bolts.

3.2.2 Mounting on a Floating Roof Tank

There are three methods of mounting the 4535 Average Temperature Converter on a floating roof tank:

1. Top anchor method
2. Stilling well method
3. Guide wire ring method

3.2.2.1 Top anchor method and stilling well method

The flexible tube is installed in a stilling well and, if required, stabilized by a top anchor. The 6000 Series Servo Tank Gauge, and the prothermo 4535 ATC can be mounted in the same stilling well.

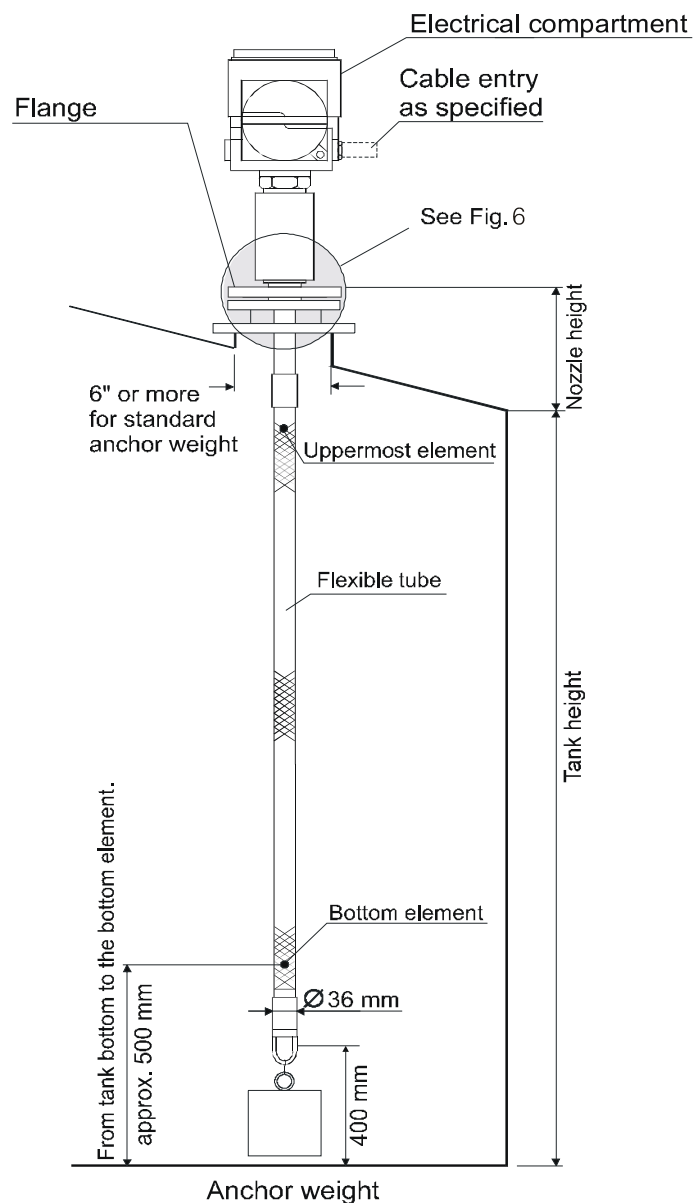

Figure 3-9: Mounting on a floating roof tank in a stilling well and/or by the top anchor method

Note! If the tank bottom is equipped with a heating coil, then increase the distance between flexible tube and bottom accordingly.

The installation procedure is same for mounting on a fixed roof tank by the top anchor method.

3.2.2.2 Guide Wire Ring Method

The flexible tube is stabilized by a gauge ring and an anchor weight.

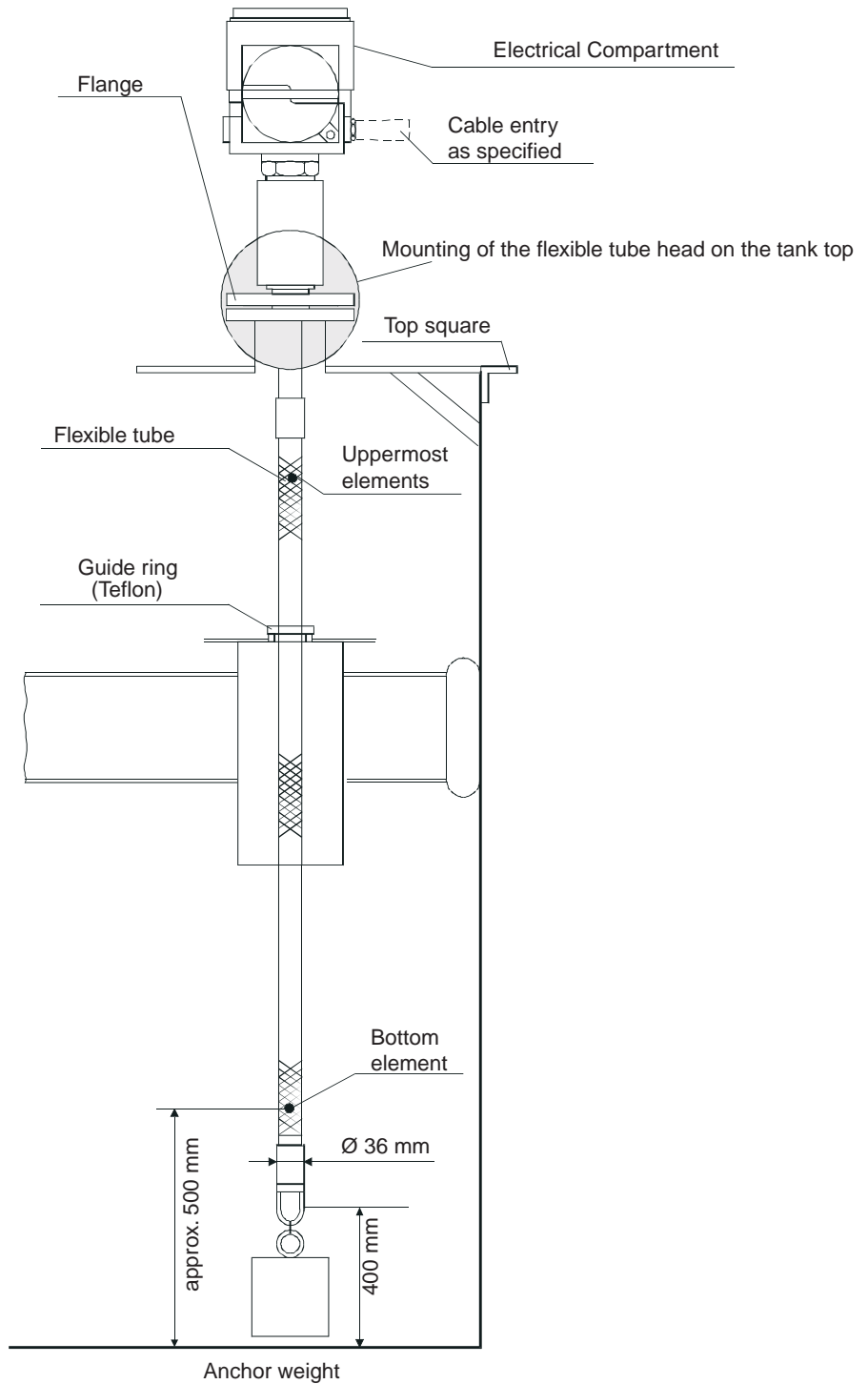

Figure 3-10: Mounting on a floating roof tank by the guide ring method

Note! If the tank bottom is equipped with a heating coil, then increase the distance between flexible tube and the tank bottom accordingly.

The installation procedure comprises the following steps:

1. Set the guide ring to the floating roof.
2. Install a gasket and lower the flexible tube into the nozzle on the tank top.

Caution! The flexible tube must be lowered carefully to prevent damage by touching the nozzle.

3. Rotate the 4535 Average Temperature Converter for the most convenient cabling position.
4. Tighten the tensioning wire between the lower end of the flexible tube and the anchor weight. Wind the tensioning wire two rounds to the hitch and wrap a commercial wire around it.

Note! Make sure that the anchor weight is hanging steadily about 10...15 mm above the tank bottom. The exact distance depends on the tank height and the type of liquid.

5. Fix the mounting flange of the 4535 Average Temperature Converter to the nozzle on the tank top by bolts.

4 Wiring

4.1 Required Cabled Ground and Cable

The following table shown the cable ground and cable that are required for the installation of the 4535 Average Temperature Converter (ATC).

If you use an unsecured wire, then equip it with a conduit pipe.

Caution! Do not connect "+" and "-" in reverse.

4.2 Wiring Procedure

1. Connect the cable from the 6000 Series Servo Tank Gauge to the terminal in the terminal box.

We recommend a crimped connection to the terminal block.

2. Connect the screen of the cable to "FG" (the silver part on the printed circuit board beneath the terminal block).

3. When the wiring procedure is finished, close the terminal box cover tight.

4. Hook the lock (shroud) thoroughly while cabling, check the cable drawing of the terminal box cover and electric box cover supplied by Sakura Endress.

Tighten the cable ground.

Caution! During cabling, thoroughly, check the cable drawing supplied by Varec.

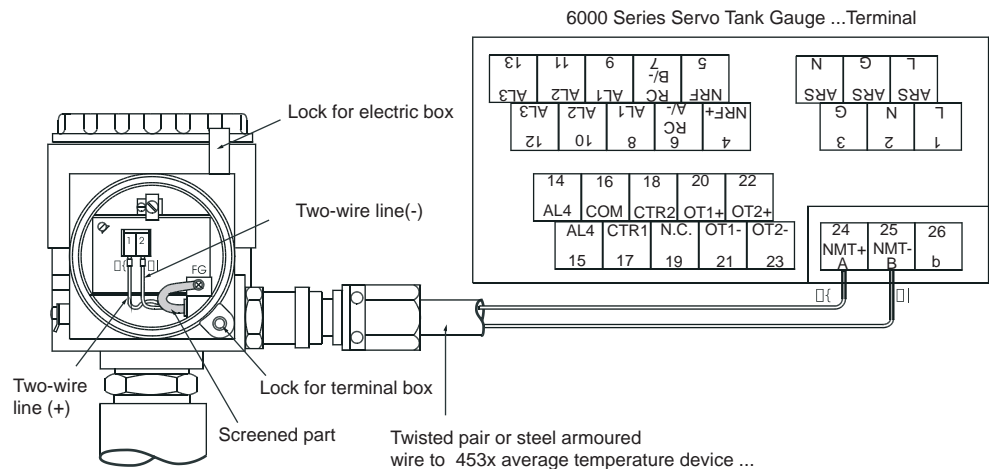

Figure 4-1: Electrical connection from the 4535 Average Temperature Converter to the 6000 Series Servo Tank Gauge

5 Operation

5.1 Operating on Matrix While Connected to the 6000 Series Servo Tank Gauge

When a 4535 Average Temperature Converter (ATC) is connected to a 6000 Series Servo Tank Gauge, information on temperature within the tank can be displayed on the 6000 Series Servo Tank Gauge. This procedure requires a special matrix operation on the 6000 Series Servo Tank Gauge, as described in the following sections.

5.1.1 Display and Operating Elements

5.1.1.1 Display

The 6000 Series Servo Tank Gauge has an illuminated LCD that consists of two lines with 16 characters each. During normal operation, it shows the level, the temperature, and the status of the device on the "HOME" position. The display of the HOME position will be explained in section 5.1.3 on page 25.

Besides "HOME" position, the 6000 Series Servo Tank Gauge is able to display other data and program various parameters with three optical keys. Please refer to section 5.4 on page 33 for the definition of each display.

5.1.1.2 Operating elements

The 6000 Series Servo Tank Gauge is operated by three optical operating elements, namely the keys

+, **-** and **E**. They are actuated by finger touch ("Touch Control") through the protective glass on the front panel; therefore, they do not accept any spontaneous and accidental input, such as direct sunlight, snow flakes, and shadow. The software and hardware installed in the 6000 Series Servo Tank Gauge rule out any malfunction that may be caused in these conditions. Even in explosive hazardous areas, the explosion-proof housing of the touch control ensures safe access to the data.

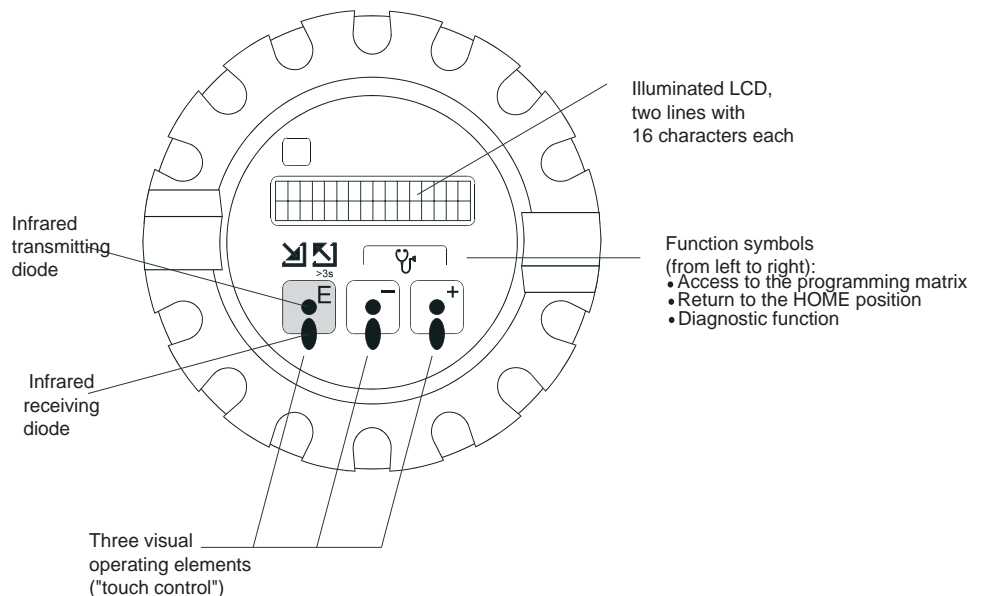







Figure 5-1: Display and operating elements





5.1.2 Functions of the Operating Elements

Establishing the operation parameter of 6000 Series Servo Tank Gauge is initiated at the programming matrix.

The programming matrix consist of:

Key	Function
	<ul style="list-style-type: none"> • Access to the programming matrix (touching  for more than 3 sec.) • Return to the HOME position (touching  for more than 3 sec.) • Moving horizontally within a function group to select functions. • Saving parameters, set values, or access code.
 	<ul style="list-style-type: none"> • Moving vertically to select function groups. • Selecting or setting parameters. • Setting access code.

Note! The LCD will return to the HOME position if no key is touched for more than 10 min.

- Digits are incremented or decremented by  or  , respectively. If you touch  or  continuously, then the minimum digit will change first. After one cycle of the minimum, the second minimum will change. After one cycle of the second follows the third minimum, and so on. If you take your finger from the touch control, then the procedure will start again from the minimum digit. (Analogy of mechanical counter)

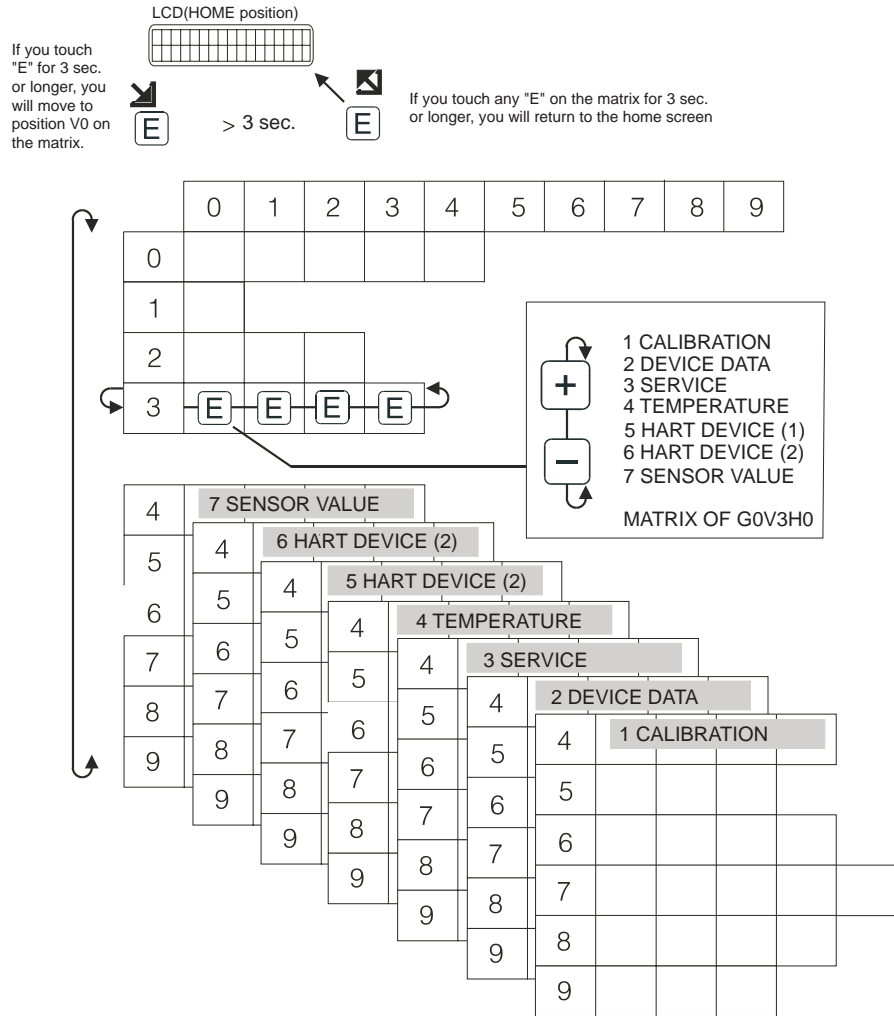

Figure 5-2: Selecting matrix groups, function groups, and function within the programming matrix

5.1.3 HOME position

After switching on the power supply, the LCD first shows the current data on the HOME position. Its pattern is represented below, where # denotes a digit or minus sign, and denotes a letter or hyphen.

The letter A,B,C and D stand for the areas where information on measured values and status of the device is displayed:

Area	Information
A	Current level
B	Current temperature
C	Gauge status
D	Displacer status

5.1.4 Access Code

The purpose of the access code is to secure the installed data. There are three security level for functions of the 6000 Series Servo Tank Gauge. The following table shows the corresponding access code.

Security level		Access code
0	-	None
1	for operator	50
2	for engineer	51

The higher levels include the lower ones, e.g. if access code 50 is specified for a function, then code 51 also enables editing. A function that requires access code 51, on the contrary cannot be edited by code 50.

Display of data or set values for security levels 0 and 1 is available without code.

However, a display of security level 2 is not available without presetting of the access code 51.

5.1.4.1 Setting an access code

To display 4535 Average Temperature Converter data on the 6000 Series Servo Tank Gauge screen, perform the following procedure.

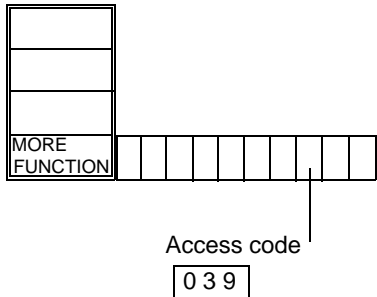
Item	Procedure	Remarks
<p>Static matrix</p> 	<ol style="list-style-type: none"> At the static matrix "MORE FUNCTION" select G0V3H9 "ACCESS CODE". The default value is "0" keep touching "+" until you get to "50" or "51". The first digit increases to 9, then the second digit increases. Stop touching "+" once you reach "50". "50" is blinking. Gently touch "+" again to increase the second digit from 0 to 1. Now you have "51" Here touch "E", "EDITING ENABLE" will be displayed. 	<ol style="list-style-type: none"> When you touch "E" While displaying an Access code except 0, 50 or 51 "EDITING ENABLE" will appear. If access code has not been selected before performing any setting, the screen will automatically change to show "EDITING ENABLED". Select "50" or "51" according to the matrix table.

5.1.5 Description of the Programming Matrix

The rows 0...3 of the programming matrix are called the static matrix. Its function is to display or allow programming of mainly measured values (primary variables) and basic operation of the 6000 Series Servo Tank Gauge.

The rows 4...9 exist on six different "pages" called the dynamic matrix. These matrix groups are labeled as follows;

STATIC MATRIX

- STATIC (V0-V3) or DYNAMIC MATRIX (V0 - V3)
- CALIBRATION (G1V4 - G1V9)
- DEVICE DATA (G2V4 - G2V9)
- SERVICE (G3V4 - G3V9)
- TEMPERATURE (G4V4 - G4V9)
- HART DEVICE (1) (G5V4 - G5V9)
- HART DEVICE (2)

SENSOR VALUE

* G = Group

* V = Vertical

* H = Horizontal

Their function to display or allow programming of parameters that are required for operation and commissioning of the 6000 Series Servo Tank Gauge and/or the 4535 ATC. As already indicated in "Selecting matrix groups, function groups, and functions within the programming matrix", the dynamic matrix is selected at position G0V3H0 "MATRIX OF" of the static matrix

The individual functions of the matrix groups are described on the following pages.

The index number in the last column denotes matrix group (0 for the static matrix, 1...6 for the dynamic matrix), vertical position (or "FUNCTION GROUP"), and horizontal position (or "ITEM") of the function.

5.2 Setting the Matrix on a 6000 Series Servo Tank Gauge

To display 4535 Average Temperature Converter data on the 6000 Series Servo Tank Gauge screen, perform the following procedure.

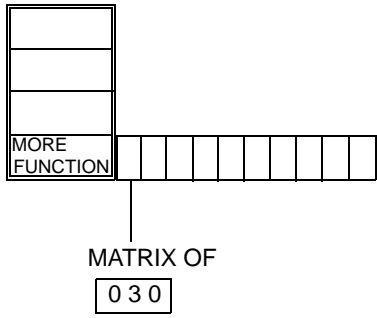
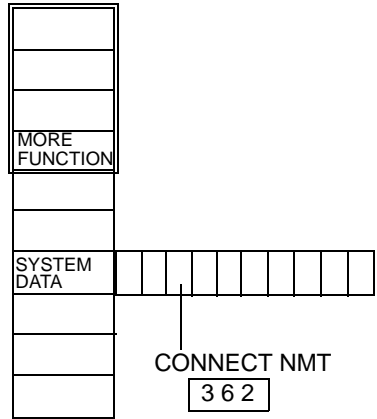
Item	Procedure	Remarks
<p>Static matrix</p>  <p>Matrix group: SERVICE</p> 	<ol style="list-style-type: none"> At the static matrix "MORE FUNCTION", call GOV3H0 "MATRIX OF", then select "SERVICE". Call up "CONNECTION NMT" on Dynamic matrix G3V6H2. Use "+" and "-" keys to display "AVERAGE", and touch "E" to return to "MORE FUNCTION". Touch "E" to return to "SYSTEM DATA". Keep touching "E" to return to "MORE FUNCTION" Call up "MATRIX OF" on Static matrix GOV3H0. From the six matrix groups on 6000 Series Servo Tank Gauge, select "TEMPERATURE". The average liquid temperature is shown on Dynamic matrix G4V4H0. The temperature at each point can be displayed on Dynamic matrixes G4V5H0 through G4VSH9. 	<ul style="list-style-type: none"> Set the access code to "51" The average temoerature will also be displayed at "LIQUID TEMP". on Static Matrix GOV1H0.

Caution! Refer to the operating manual for 6000 Series Servo Tank Gauge, when setting the matrix on 6000 Series Servo Tank Gauge.

5.3 Programming Matrix

This section shows the complete programming matrix of 6000 Series Servo Tank Gauge (necessary for 4535 ATC only). Each matrix group appears on a separate page. The functions are described in the following chart:

Caution! This section shows only the 6000 Series Servo Tank Gauge programming matrix which is needed to operate the 4535 Average Temperature Converter.

5.3.1 Matrix G0 Static matrix

GROUP MESSAGE	H		V		1		2		3		4		5		6		7		8		9		
	0	1	0	1	0	1	0	1	0	1	0	1	0	1	0	1	0	1	0	1	0	1	
MEASURED VALUE 1	16000.00 mm MEASURED LEVEL Display	0.0 mm ULLAGE LEVEL Display	0.0 mm UPPER INTERF. LEV Display	0.0 mm MIDD. INTERF. LEV Display	0.0 mm BOTTOM LEVEL Display	1.000 g/ml UPPER DENSITY Display/Set (50)	1.000 g/ml MIDDLE DENSITY Display/Set (50)	1.000 g/ml DENSITY BOTTOM Display/Set (50)	0.0 mm LEVEL DATA Display	0.0 mm SPAN Display	16000.0 mm LENGTH UNIT Display	OFF STATUS1 ON Display											
MEASURED VALUE 2	0.0°C LIQUID TEMP Display	0.0°C DEV(1) Display	0.0°C DEV(2) Display	0.0°C GAS TEMPERATURE Display																			
OPERATION	STOP OPERATION 16000 See below operation commands Select (50)	STOP OPERATING STATUS See below status table Display	UNBALANCED BALANCING STATUS Display		LEVEL OPERAT.BY NRF Display	LEVEL OPERAT.BY HOST Display														411 DEVICE ID Display	8424 SOFTWARE VERSION Display		
MORE FUNCTION	CALIBRATION MATRIX OF Select			98 627 8;21:00 CALENDER Current data Display	NO ALARM ALARM CONTACT Current data Display	NO ALARM OPERAT.BY HOST Display	NO ERROR DIAGNOSTIC CO Current data Display	MPU: START ACT 98 627 752 0 0 Current data Display															0 ACCESS CODE 0.50.51.777 Set

5.3.2 Matrix G4 Temperature matrix (Dynamic)

GROUP MESSAGE	H	V	0	1	2	3	4	5	6	7	8	9
TEMPERATURE DATA	4		xx °C LIQUID TEMP Current data Display (51)	zz °C GAS TEMPERATURE Current data Display (51)	aaaa mm MEASURED LEVEL Current data Display (51)	VH00 LEV DATA SELECT VH08 Select (51)				0.0 °C REFERENCE ZERO Current data Display (51)	152.5 °C REFERENCE JPT15 Current data Display (51)	150.0 °C REFERENCE 150 Current data Display (51)
ELEMENT TEMP.	5		aa.a °C TEMP. NO.1 Current data Display (51)	bb.b °C TEMP. NO.2 Current data Display (51)	cc.c °C TEMP. NO.3 Current data Display (51)	dd.d °C TEMP. NO.4 Current data Display (51)	ee.e °C TEMP. NO.5 Current data Display (51)	ff.f °C TEMP. NO.6 Current data Display (51)	gg.g °C TEMP. NO.7 Current data Display (51)	hh.h °C TEMP. NO.8 Current data Display (51)	ii.i °C TEMP. NO.9 Current data Display (51)	jj.j °C TEMP. NO.10 Current data Display (51)
ELEMENT POSITION	6		xxx.x mm ELEM.1 POSITION Current data Display (51)	xxx.x mm ELEM.2 POSITION Current data Display (51)	xxx.x mm ELEM.3 POSITION Current data Display (51)	xxx.x mm ELEM.4 POSITION Current data Display (51)	xxx.x mm ELEM.5 POSITION Current data Display (51)	xxx.x mm ELEM.6 POSITION Current data Display (51)	xxx.x mm ELEM.7 POSITION Current data Display (51)	xxx.x mm ELEM.8 POSITION Current data Display (51)	xxx.x mm ELEM.9 POSITION Current data Display (51)	xxx.x mm ELEM.10 POSITION Current data Display (51)
NMT ADJUSTMENT	7		0 SELECT POINT 0 - 15 Selectable SELECT POINT + 1 = ELEMENT No. Set (51)	0.0 °C ZERO ADJUST Set (51)	1.000 GAIN ADJUST Set (51)	xx.x °C ELEMENT TEMP Current data Display (51)	xxx.x mm ELEMENT POSITION Current data Display (51)				2 AVERAGE TIME Set (51)	530 ACCESS CODE Display (51)
SET DATA NMT	8		0 DIAGNOSTIC Display (51)		16 TOTAL NO.ELEMENT 2 - 16 Set (51)	5 PREAMBLE NUMBER 1 - 16 Set (51)		EQUAL KIND OF INTERVAL UNEQUAL Set (51)	500.0 mm BOTTOM POINT 0.0 mm to 500.0 mm valuable Set (51)	2000.0 mm ELEMENT INTERVAL Set (51)	49.5 °C TEMP.ELEM.SHORT Display (51)	359.0 °C TEMP.ELEM.OPEN Display (51)
DEVICE DATA NMT	9		825123 INSTRUMENT CODE Display (51)			2 POLLING ADDRESS Display (51)	17 MANUFACTURE ID Display (51)	5 SOFTWARE VERSION Display (51)	2 HARDWARE VERSION Display (51)	2 ON BELOW BOT. POINT OFF Set (51)	183 DEVICE TYPE CODE 181 Display (51)	

5.3.3 Matrix G7 Adjust Sensor matrix (Dynamic)

GROUP MESSAGE	H V	0	1	2	3	4	5	6	7	8	9
ADJ. SENSOR	4	ADJ. A ZERO	ADJ. A SPAN	ADJ. B ZERO	ADJ. B SPAN						
HART ERROR RATE	5	0.00% ERR. RATE NMF	0.00% ERR. RATE NMT	0.00% ERR. RATE DEV(1)	0.00% ERR. RATE DEV(2)						
UNIT	6	mm LEV. UNIT (HOST)	°C TEMP. UNIT (HOST)	g/ml DEN. UNIT (HOST)			mm LEV. UNIT	°C TEMP. UNIT	g/ml DEN. UNIT		
HART LINE	7	TERMINAL PORT B NMT TERMINAL PORT A Select (777)	TERMINAL PORT B HART DEVICE (1) TERMINAL PORT A Select (777)	TERMINAL PORT B HART DEVICE (2) TERMINAL PORT A Select (777)							
INTERFACE ADJUST	8	0.3 mL VOLTOL FOR I/F 0 - 99.9 mL Set (51)	150 BRAKE RATE 0 - 255 Set (51)	15 BALANCE COUNT 0 - 255 Set (51)	0.0 mm IF1 OFFSET 0 - 9999.9 mm Set (51)	0.0 mm IF2 OFFSET 0 - 9999.9 mm Set (51)					
NONE	9										

5.4 Description of the Programming Matrix

The programming matrix of the 4535 ATC is mainly designed to configure from the 6000 Series Servo Tank Gauge. Commissioning from the 4590 TSM or any other HART device may perform differently. Please refer to each designated operation manual for detailed information. For detailed information on touch control and programming matrix, refer to the operating manual of the 6000 Series Servo Tank Gauge.

Matrix group	Function group	Item	Access code	Short description	Default Value	Set Select Display	Possible settings, or displays	Index No. GVH	
STATIC MATRIX (This word is not shown)	MEASURED VALUE 2	LIQUID TEMP.	0	If a temperature bulb is connected, then this position shows the measured liquid temperature. Otherwise the LCD will be blank.	0.0 °C	Display	-49.9 ... 249.9 °C	010	
		GAS TEMPERATURE	0	If a temperature bulb is connected, then this positionj shows the measured gas temperature.	0.0 °C	Display	-49.9 ... 249.9 °C	013	
SERVICE	MORE FUNCTION	MATRIX OF	0	Selection of the dynamic matrix of the programming matrix	CALIBRATI NO	Select	CALIBRATION DEVICE DATA SERVICE TEMPERATURE HART DEVICE (1) HART DEVICE (2) ADJ. SENSOR	030	
		(Calendar)	0	Calendar and clock without daylight saving system. NOT TRANSFERRED BY RACKBUS.	Japanese local time	Display	e.g. 1 410 19:10.41 Year Month Day HH:MM:SS	033	
		DIAGNOSTIC CO	0	Self diagnosis at the moment		Display	Error message (refer to attached table)	036	
		(Erroneous Message)	0	Previous alarm with message. Only the last alarm code is transmitted by Rackbus.	(Erroneous Date)	Display	Error message (refer to attached table)	037	
		ACCESS CODE	0	Access code for programming (see Sec. 10.4)	0	Set	0 ... 9999	039	
		CONNECTION NMT	51	Connection of the 4535 ATC	OFF	Select	OFF SPOT (three wire RTD input) Average (4535 ATC)	362	

Matrix group	Function group	Item	Access code	Short description	Default Value	Set Select Display	Possible settings, or displays	Index No. GVH
TEMPERATURE Note! The whole matrix is available when the 4535 ATC is connected and SPOT or AVERAGE temperature element is selected	TEMPERATURE DATA	LIQUID TEMP.	51	Current average liquid temperature		Display	-49.9 ... 249.9 °C	440
		GAS TEMPERATURE	51	Current average gas temperature		Display	-49.9 ... 249.9 °C	441
		MEASURED LEVEL	51	Level from the 6000 Series Servo Tank Gauge. The level data are used for the averaging of liquid and gas temperatures.		Display	0.0 ... 99999 mm	442
	LEV. DATA SELECT	51	Possible to select a measured level data from matrix position GVH=0000 (displacer position), or GVH=008 (level data after balanced).	VH00	Display	VH00 VH08	443	
	REFERENCE ZERO	51	Display of reference resistance on printed circuit board that corresponds to 0 °C.	0.0 °C	Display		447	
	REFERENCE JPT150	51	Display of reference resistance on printed circuit board that corresponds to JPT 150 °C.	152.5 °C	Display		448	
	REFERENCE 150	51	Display of reference resistance on printed circuit board that corresponds to 150 °C.	150.0 °C	Display		449	
	TEMP NO. 1	51	Temperature of element No. 1 (deepest point)		Display	-49.9 ... 249.9 °C	450	
	TEMP NO. 2	51	Temperature of element No. 2		Display	-49.9 ... 249.9 °C	451	
	TEMP NO. 3	51	Temperature of element No. 3		Display	-49.9 ... 249.9 °C	452	
TEMP NO. 4	51	Temperature of element No. 4		Display	-49.9 ... 249.9 °C	453		
TEMP NO. 5	51	Temperature of element No. 5		Display	-49.9 ... 249.9 °C	454		
TEMP NO. 6	51	Temperature of element No. 6		Display	-49.9 ... 249.9 °C	455		
TEMP NO. 7	51	Temperature of element No. 7		Display	-49.9 ... 249.9 °C	456		
TEMP NO. 8	51	Temperature of element No. 8		Display	-49.9 ... 249.9 °C	457		
TEMP NO. 9	51	Temperature of element No. 9		Display	-49.9 ... 249.9 °C	458		
TEMP NO. 10	51	Temperature of element No. 10		Display	-49.9 ... 249.9 °C	459		
	ELEMENT TEMP. Note! For elements with numbers beyond the value set at GVH=482, the LCD will show 358.0 °C.							

Matrix group	Function group	Item	Access code	Short description	Default Value	Set Select Display	Possible settings, or displays	Index No. GVH
TEMPERATURE Note! The whole matrix is available when 4535 ATC is connected and SPOT or AVERAGE temperature element is selected	ELEMENT POSITION Note! The LCD shows the element position measured from the tank bottom (for previously set elements only).	ELEM. 1 POSITION	51	Position of temperature element No. 1 (deepest point), namely Bottom Element	500 mm	Display	0 ... 99999 mm	460
		ELEM. 2 POSITION	51	Position of temperature element No. 2	2500 mm	Display	0 ... 99999 mm	461
		ELEM. 3 POSITION	51	Position of temperature element No. 3	4500 mm	Display	0 ... 99999 mm	462
		ELEM. 4 POSITION	51	Position of temperature element No. 4	6500 mm	Display	0 ... 99999 mm	463
		ELEM. 5 POSITION	51	Position of temperature element No. 5	8500 mm	Display	0 ... 99999 mm	464
		ELEM. 6 POSITION	51	Position of temperature element No. 6	10500 mm	Display	0 ... 99999 mm	465
		ELEM. 7 POSITION	51	Position of temperature element No. 7	12500 mm	Display	0 ... 99999 mm	466
		ELEM. 8 POSITION	51	Position of temperature element No. 8	14500 mm	Display	0 ... 99999 mm	467
		ELEM. 9 POSITION	51	Position of temperature element No. 9	16500 mm	Display	0 ... 99999 mm	468
		ELEM. 10 POSITION	51	Position of temperature element No. 10	185000 mm	Display	0 ... 99999 mm	469
NMT ADJUSTMENT		SELECT POINT	51	Element number selection for reading element temperature and position from element No. 11 to No. 16	0	Display	0 (element No. 1) 10 (element No. 11)	470
		ZERO ADJUSTMENT	51	Zero adjustment		Set	-20.0 ... 20.0 °C	471
		ELEMENT TEMP.	51	Element temperature selected at "SELECT POINT"		Display	-49.9 ... 249.9 °C	473
		ELEMENT POSITION	51	Element position selected at "SELECT POINT"		Display	0 ... 99999 mm	474
		AVERAGING	51	Sampling coefficient for averaging of data. If there is a high degree of instability due to noise or other factors, increase its value.	2	Set	1 ... 10	478

Matrix group	Function group	Item	Access code	Short description	Default Value	Set Select Display	Possible settings, or selections, or displays	Index No. GVH
TEMPERATURE Note! The whole matrix is available when 4535 ATC is connected and SPOT or AVERAGE temperature element is selected	NMT SET DATA	DIAGNOSTIC CODE	51	Display of current diagnostic code.	0	Dispaly	0 ... 255	480
		TOTAL NO. ELEMENT	51	The total number of elements that are mounted in the flexible tube. This number is determined in accordance with the specifications provided when the order of the device is placed.	16	Set	a ... A HEX	482
		PREAMBLE NUMBER	51	Display of preambles for HART® protocol	5	Display	2 ... 14 HEX	483
		KIND OF INTERVAL	51	Temperature element intervals - Equal intervals: 0 - Unequal intervals: 1 If 1 is chosen, then set the element position on matrix from GVH=460 to GVH=469	0	Set	0 or 1	485
		BOTTOM POINT	51	Height of bottom point Only available when equal intervals are selected.	500 mm	Set	0.0 ... 99999.9 mm	486
		ELEMENT INTERVAL	51	Interval between temperature elements. Only available when equal intervals are selected.	2000 mm	Set	0.0 99999.9 mm	487
		TEMPERATURE AT SHORT ELEMENT	51	Temperature indication when element is shorted. This value is sent at the 6000 only when the error output is "ON" at GVH=492. When the error output is "OFF", the average temperature is sent to the 6000 Series Servo Tank Gauge.	-49.5 °C	Set		488
		TEMPERATURE AT OPEN ELEMENT	51	Temperature indication when element is opened. This value is sent to the 6000 Series Servo Tank Gauge only when the error output is "ON" at GVH=492. When the error output is "OFF", the average temperature is sent to the 6000 Series Servo Tank Gauge.	359.0 °C	Set		489

Matrix group	Function group	Item	Access code	Short description	Default Value	Set Select Display	Possible settings, or displays	Index No. GVH
TEMPERATURE Note! The whole matrix is available when the 4535 ATC is connected and SPOT or AVERAGE temperature element is selected	NMT DEVICE DATA	INSTRUMENT CODE	51	Display of the hardware unit number		Display		490
		LAST DIAGNOSTIC	51	Display of the last error message. If there was no error, then the LCD will be blank.		Display		491
		OUTPUT AT ERROR	51	Selection of output and indication in case of short circuit or open circuit elements at GVH=488 or 498.	1	Select	0: OFF 1: On	492
		CUSTODY TRANSFER	51	Custody transfer mode. If this mode is switched on, then the LCD will shown on.	OFF	Select	OFF ON	493
		POLLING ADDRESS	51	Assignment of an address to 4535 ATC when this and other HART devices are multi-dropped on the HART communication line. Polling address 2 is fixed by 6000 Series Servo Tank Gauge firmware.	2	Set	1 ... F (Total 16 address can be set.)	494
		MANUFACTURER ID	51	Identification number of the manufacturer (17 for Varec).	17	Display		495
		SOFTWARE VERSION	51	Software version of the 4535 ATC.	5.0	Display		496
		HARDWARE VERSION	51	Hardware version of the 4535 ATC.	1.4	Display		497
		DEVICE TYPE CODE	51	Display of the device type code (181 for the 4535 ATC)	181	Display		499
		ADJ. SENSOR	UNIT	TEMP. UNIT (HOST)	51	Able to switch displaying unit for remote receiving host system.	°C	Select
TEMP. UNIT	51			Able to switch displaying unit for 6000 Series Servo Tank Gauge & 6000 Series Servo Tank Gauge connected local HART displaying unit.	°C	Select	°C, °F, °R, °K	766
	HART LINE	NMT	777	Assignment of 4535 ATC with IS HART or Non-IS HART connection.	TERMINAL PORT B	Set	TERMINAL PORT B TERMINAL PORT A	770

A Order Structure

4535 Average Temperature Sensor and Converter

10	Protection class			
	0	IP 67		
	4	XP class 1, Div. 1, Gr.CD, FM		
	7	IS Class 1, Div 1, Gp. CD, FM		
	9	Special version		
20	Cable Entry			
	A	One G(PF) 1/2" thread		
	B	One NPT 1/2" thread		
	C	One PG 16 (only Protection class 0)		
	D	One M 20 thread		
	Y	Special version		
30	Process connection, material			
	0	JIS 10K 50A RF flange		
	1	ANSI 2" 150lbs RF flange		
	2	DIN DN50 PN10 RF flange		
	3	JPI 2" 150lbs RF flange		
	9	Special version		
40	Flange material			
	0	Mild steel (JIS SS400) flange		
	1	Stainless steel (SS304) flange		
	9	Special version		
50	Measuring range			
	1	-50 to +200 °C, -58 to +392 °F (wide range)		
	2	-20 to +100 °C, -4 to +212 °F (standard range)		
	3	-18 to + 80 °C, 0 to +176 °F (PTB W&M)		
	9	Special version		
60	Number of element			
	A	Two Pt100		
	B	Three Pt100		
	C	Four Pt100		
	D	Five Pt100		
	E	Six Pt100		
	F	Seven Pt100		
	G	Eight Pt100		
	H	Nine Pt100		
	J	Ten Pt100		
	K	Eleven Pt100		
	L	Twelve Pt100		
	M	Thirteen Pt100		
	N	Fourteen Pt100		
	O	Fifteen Pt100		
	P	Sixteen Pt100		
	Y	Special version		
70	Element spacing			
	1	Element Spacing: 2000mm		
	2	Element Spacing: 1500mm		
	3	Element Spacing: 1000mm		
	4	Elements equally spaced defined by length and element number		
	5	Element Spacing: 3000mm		
	9	Special version		
80	1,000 to 40,000mm probe length (below flange)			
	Amm probe length		
	Y	Special version		
90	Display			
	A	No display		

100															Mounting attachment
															A Without installation material, for guide pipe installation
															B With anchor weight for CRT
															D With tensioning wire, anchor weight, top anchor (threaded NPT 1")
															Y Special version
4535 ATC-															Complete product designation

B Temperature Ranges and Element Tolerances

The allowable temperature range is determined by the following tolerances. (These are not equations.)

Measured temperature	Tolerance	
	Ω	C
-20	± 0.24	± 0.55
-100	± 0.14	± 0.35
0	± 0.16	± 0.15
100	± 0.13	± 0.35
200	± 0.20	± 0.55
300	± 0.27	± 0.75
400	± 0.33	± 0.95
500	± 0.38	± 1.15
600	± 0.43	± 1.35
650	± 0.46	± 1.45
700	-	-
800	-	-
850	-	-

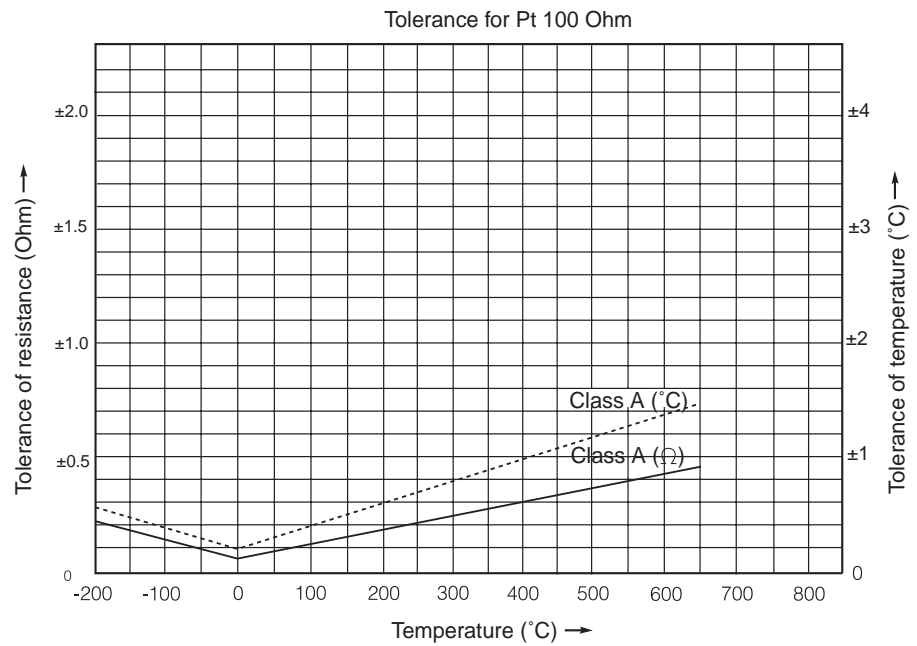

Contact us if you wish to purchase any tolerance resistance element that is not on this standard products list

C Error Codes

If an error has occurred in the 4535 ATC, then the 6000 Series Servo Tank Gauge will display an error message and also send error information to the receiver.

C.1 Short Circuit or Break

After a short circuit or break in the elements or the wiring, the 4535 ATC display an extreme temperature such as

-49.5°C (-57.1°F)... default for short circuit)

or

359.0°C (678.2°F)... default for break

on the HOME position of the 6000 Series Servo Tank Gauge and transferring it to a remote system for convenient monitoring function for the faulty condition. These temperatures will only be displayed while the element at fault is selected.

If you select a faultless element, then the LCD will show the correct average temperature. Setting is possible at positions G0V8H8/9 and G0V9H2 of the programming matrix.

C.2 Communication Error

After a communication error between the 4535 ATC and the 6000 Series Servo Tank Gauge (HART® communication error), the 6000 Series Servo Tank Gauge will display 395.5°C (743.9°C) on the HOME position of the 6000 Series Servo Tank Gauge.

C.3 Error and Status Messages

Message	Cause	Remedy
TEMP.COM.OPEN	Common line for elements break	Check the common line for elements. Consult Varec Service for replacement of the temperature sensor.
TEMP.COM.SHORT	Common line for elements short circuit.	Check the common line for elements. Consult Varec Service for replacement of the temperature sensor
ELEM. X OPEN X = 1...16	No. X element (or line) break	Check the element. Measure the resistance by attaching a Digital Multimeter rod to the connector.(*)
ELEM. X SHORT X = 1...16	No. X element (or line) short circuit	Check the element. Measure the resistance by attaching a Digital Multimeter rod to the connector.(*)

(*) Never use an analog-type tester, which would allow too much electric current to flow to the measuring element when determining the resistance. The current should be limited to 1 mA or less during such test.

Message	Cause	Remedy
ELEM O RANGE OVER	The reading of the reference resistance (0 C) on the printed circuit board is out of tolerance.	The circuit board should be replaced
TEM BELOW RANGE	The measured temperature is below the set range.	Measure the temperature in the tank. If it is significantly different from the indicated 4535 ATC setting, check the temperature-element resistance.
TEM OVER RANGE	The measured temperature is above the set range.	Measure the temperature in the tank. If it is significantly different from the indicated 4535 ATC setting, check the temperature-element resistance.
BELOWBOT. POINT	The level data are below the lowest (bottom) element.	The reading gives only the average gas temperature.

NOTES

Your official representative



www.varec.com

Varec, Inc.
5834 Peachtree Corners East, Norcross (Atlanta), GA 30092 USA
Tel: +1 (770) 447-9202 Fax: +1 (770) 662-8939

© 2006 Varec, Inc. An SAIC Company. All Rights Reserved. This document is for information purposes only. Varec, Inc. makes no warranties, express or implied, in this summary. The names of actual companies and products mentioned herien may be the trademarks of their respective owners.