

Multi-Element Temperature Transmitter

Highly accurate and effective transmission of temperature data

Varec[®]

Installation and Operations Manual

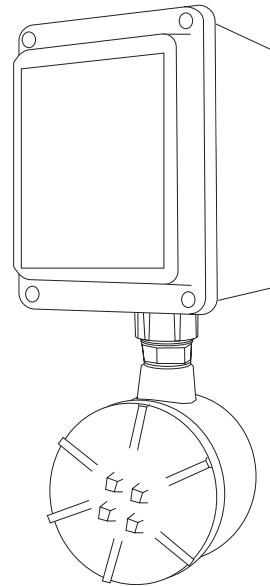

www.varec.com

Copyright

All rights reserved. Printed in the United States of America.
Except as permitted under the United States Copyright Act of 1976, no part of this publication may be reproduced, stored in a retrieval system or transmitted in any form or by any means— electronic, mechanical, photocopying, recording or otherwise— without the prior written permission of the Publisher:

Varec, Inc.
5834 Peachtree Corners East
Norcross (Atlanta), Georgia 30092
Phone: (770) 447-9202
Fax: (770) 662-8939

Trademarks acknowledged

Trademarks of other products mentioned in this manual are held by the companies producing them.

FuelsManager® is a registered trademark of
Varec, Inc.

Microsoft® is a registered trademark of Microsoft
Corporation.

Acrobat® is a registered trademark of Adobe Systems
Incorporated.

MODBUS® is a registered trademark of Modicon, Inc.

TIWAY® is a registered trademark of Texas Instruments
Corporation

Varec® is a registered trademark of Varec, Inc.

HART® interface is a registered trademark of HART
Communications Foundation

All other trademarks are acknowledged.

Disclaimer of Warranties

The contract between the Seller and the Buyer states the entire obligation of the Seller. The contents of this instruction manual shall not become part of or modify any prior or existing agreement, commitment or relationship between the Seller and Buyer. There are no express or implied warranties set out in this instruction manual. The only warranties that apply are those in the existing contract between the Seller and Buyer.

Varec Model 4120 has not been tested by Varec under all possible operational conditions, and Varec may not have all the data relative to your application. The information in this instruction manual is not all inclusive and does not and cannot take into account all unique situations. Consequently, the user should review this product literature in view of his/her application. If you have any further questions, please contact Varec for assistance.

Limitations of Seller's Liability

In the event that a court holds that this instruction manual created some new warranties, Seller's liability shall be limited to repair or replacement under the standard warranty clause. In no case shall the Seller's liability exceed that stated as Limitations of Remedy in the contract between the Seller and Buyer.

Use of parts that are not manufactured or supplied by Varec voids any Varec warranty and relieves Varec of any obligation to service the product under warranty. Varec recommends the use of only Varec manufactured or supplied parts.

Terms of Use

The information provided in this document is provided "as is" without warranty of any kind. Varec, Inc. disclaim all warranties, either express or implied, including the warranties of merchantability and fitness for a particular purpose. In no event shall Varec, Inc. or its suppliers be liable for any damages whatsoever including direct, indirect, incidental, consequential, loss of business profits or special damages, even if Varec, Inc or its suppliers have been advised of the possibility of such damages.

Safety Precaution Definitions

The following types of warnings have been categorized by Varec for this product. Read and understand this Manual before installing, operating or performing maintenance on a Model 2500 Automatic Tank Gauge. Follow all precautions and warnings noted herein when installing, operating or performing maintenance on this equipment.

Note!

Follow these specific instructions to optimize the procedure or process

Caution!

Damage to equipment may result if this precaution is disregarded.

Warning!

Direct injury to personnel or damage to equipment which can cause injury to personnel may result if this precaution is not followed.

Safety Precautions

Caution!

Read and understand static and lightning electrical protection and grounding described in API 2003. Make certain that the tank installation, operation and maintenance conforms with the practice set forth therein.

Warning

Make certain that the tank is empty and not in service. Ensure that the tank has been leak and pressure tested as appropriate for the liquid to be stored. Observe appropriate safety precautions in flammable or hazardous liquid storage areas. Do not enter a tank that has contained hydrocarbons, vapors, or toxic materials, until a gas-free environment is certified. Carry breathing equipment when entering a tank where oxygen may be displaced by carbon dioxide, nitrogen or other gases. Wear safety glasses as appropriate. Use a hard hat.

Warning!

Read and understand this instruction manual before installing, operating or performing maintenance on the Varec Model 4120 Multi-Element Temperature Transmitter. Follow all precautions and warnings noted herein when installing, operating or performing maintenance on this equipment.

Table of Contents

Copyright	2
Revision Control	2
Acknowledgments	2
Disclaimer of Warranties	3
Limitations of Seller's Liability	3
Safety Precaution Definitions	4
Safety Precautions	4
Table of Contents	5
List of Illustrations	5
Section 1 - Introduction and Installation	7
Using This Manual	7
Getting Acquainted with the Multi-Element Temperature Transmitter (METT)	7
Installation	8
Section 2 - Operation	12
Temperature Configurations	12
Temperature Averaging	12
HART Communications Interface	12
Varec Handheld Terminal Interface	13
Section 3 - Specifications and Reference Data	17
Specifications and Physical	17
Functional	17
Hazardous Location Approvals	17
Environmental	17
Performance	17
Physical	17
Model Options	18
Section 4 - MFT/HIU and TankView Support for the METT	19
MFT/HIU Support	19
TankView Support	19
Section 5 - HART Protocol Implementation	20
Transmitter Variables	20
Standard HART Commands	20
METT Device Specific HART Commands	21
Command 130 - Write Level	21
Command 131 - Read Temperature Configuration	21
Command 132 - Write Temperature Configuration	21
Command 133 - Read Temperature Element Height	22
Command 134 - Write Temperature Element Height	22
List of Illustrations	
Figure 1 Typical Model 4120 Installation with Averaging Bulb	8
Figure 2 Typical Model 4120 Installation with Multiple Spot Bulbs	8
Figure 3 Typical Model 4120 Installation with Hybrid Gauging System	9
Figure 4 Typical MFT/HART Host Communication Wiring	9
Figure 5 Typical Average Bulb Wiring	10
Figure 6 Typical Multiple RTD Wiring	10
Figure 6 Dimensional Outline	10
Figure 8 Model 4120 Component Identification	16

Section 1 - Introduction and Installation

Using This Manual

This manual describes the operation and usage of the Varec Model 4120 Multi-Element Temperature Transmitter.

- Section 1 – Introduction and Installation
- Section 2 – Operation
- Section 3 – Specifications and Reference Data
- Section 4 – MFT/HIU and TankView Support for the METT
- Section 5 – HART Protocol Implementation

Getting Acquainted with the Multi-Element Temperature Transmitter (METT)

The Varec Model 4120 Multi-Element Temperature Transmitter is designed for use with two types of tank temperature configurations.

- Multiple Averaging Temperature Bulb
- Multiple RTDs

The first configuration uses a multiple averaging element temperature bulb and is shown in Figure 1. Up to 10 elements are supported. Additionally, it has the capability to acquire temperature from top and bottom spot elements. The top spot element is used to measure the temperature of vapor space. In the averaging configuration the top and bottom probes are expected to be part of the averaging temperature bulb assembly. All temperature inputs are single wire with two common returns for all elements.

The second configuration uses multiple RTDs and is shown in Figure 2. The RTDs are mounted at different heights on the side of the tank. Up to 12 RTDs are supported. All RTDs must be of the 3-wire type and must all be of the same type. That is, they must all be copper or platinum but not a mix.

The METT converts the resistance values to engineering units and transmits the information over the HART bus. It is designed for use with the Varec Model 4100 Multifunction Transmitter, Model 4200 Hydrostatic Interface Unit or any other HART host. The ATTI version is designed to operate with the Varec Model 4000 Advanced Technology Transmitter.

Installation

The Varec Model 4120 Multi-Element Temperature Transmitter is housed in a NEMA 4X enclosure and is designed to meet FM, CSA, and CENELEC intrinsically safe approvals. The METT mounts directly to a standard (API 2543) averaging temperature bulb such as the Varec Model 9909. A junction box is included with terminal connections for the averaging bulb wires, the Handheld Interface, and the HART bus. The METT provides galvanic isolation and lightning protection between the HART bus and the temperature elements. A larger terminal box is included with three terminals for each RTD (maximum 30).

The ATTI bus version of the METT requires intrinsic safety barriers installed within a junction box because the ATTI bus is not intrinsically safe.

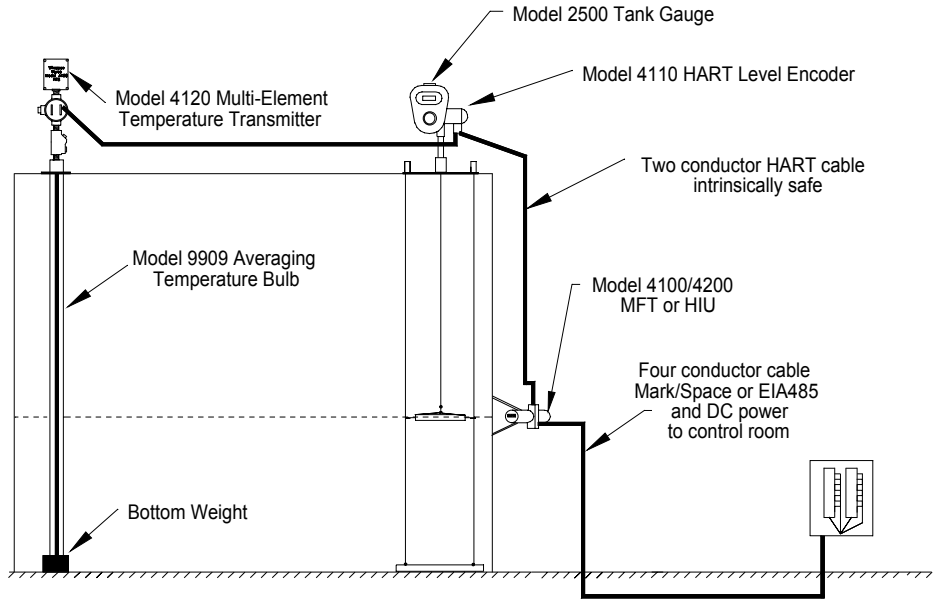

Figure 1 Typical Model 4120 Installation with Averaging Bulb

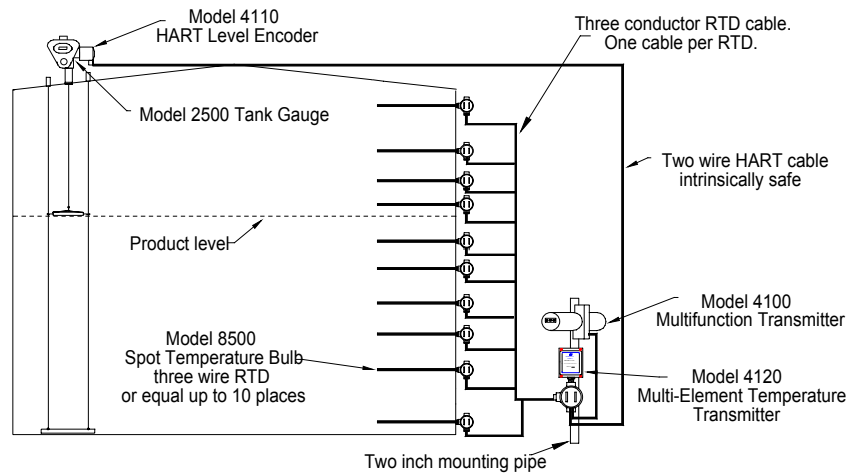

Figure 2 Typical Model 4120 Installation with Multiple Spot Bulbs

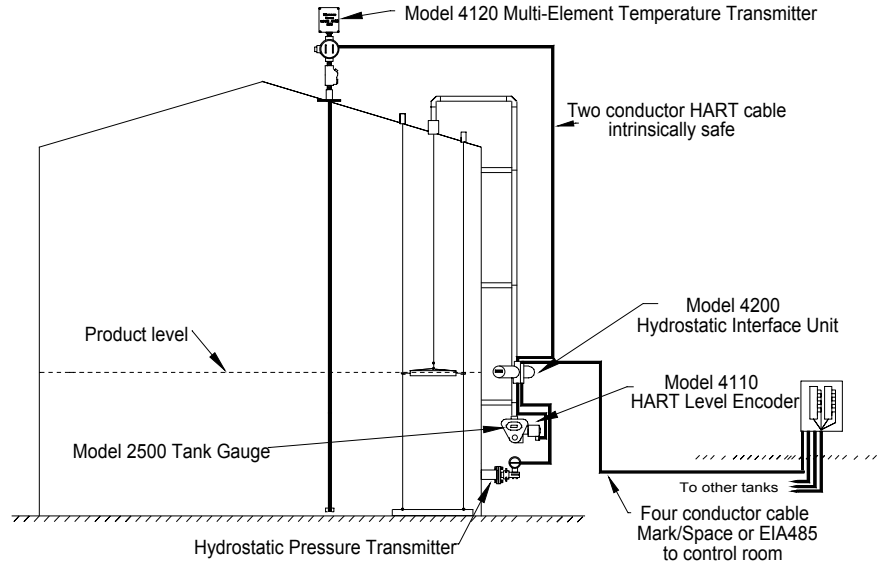

Figure 3 Typical Model 4120 Installation with Hybrid Gauging System

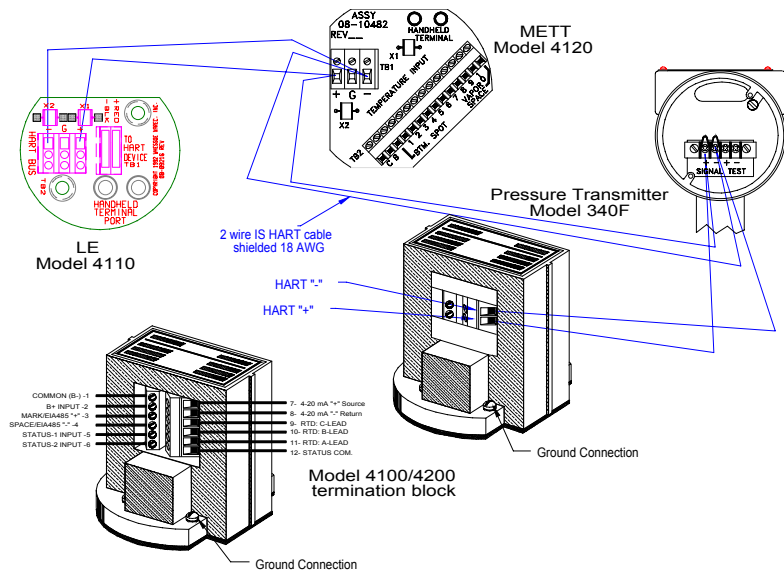
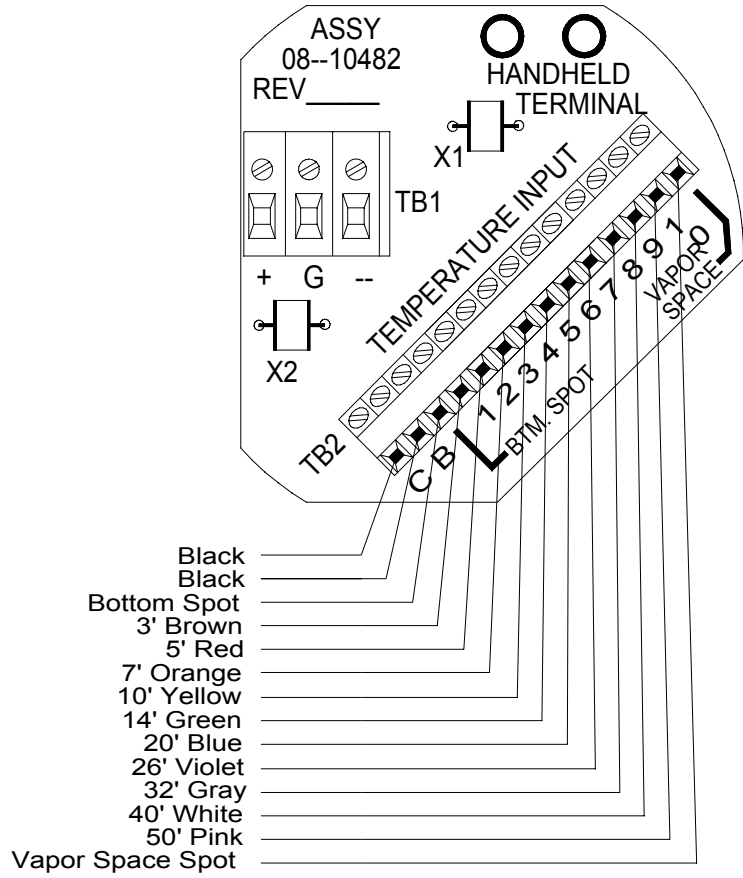

Figure 4 Typical MFT/HART Host Communication Wiring



Colors shown for Whessoe Varec Model 9909 Averaging Temperature Bulb

Figure 5 Typical Average Bulb Wiring

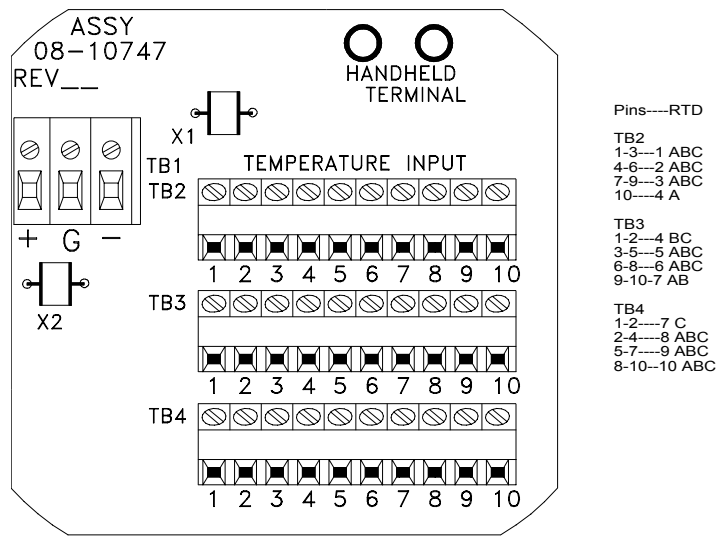

Figure 6 Typical Multiple RTD Wiring

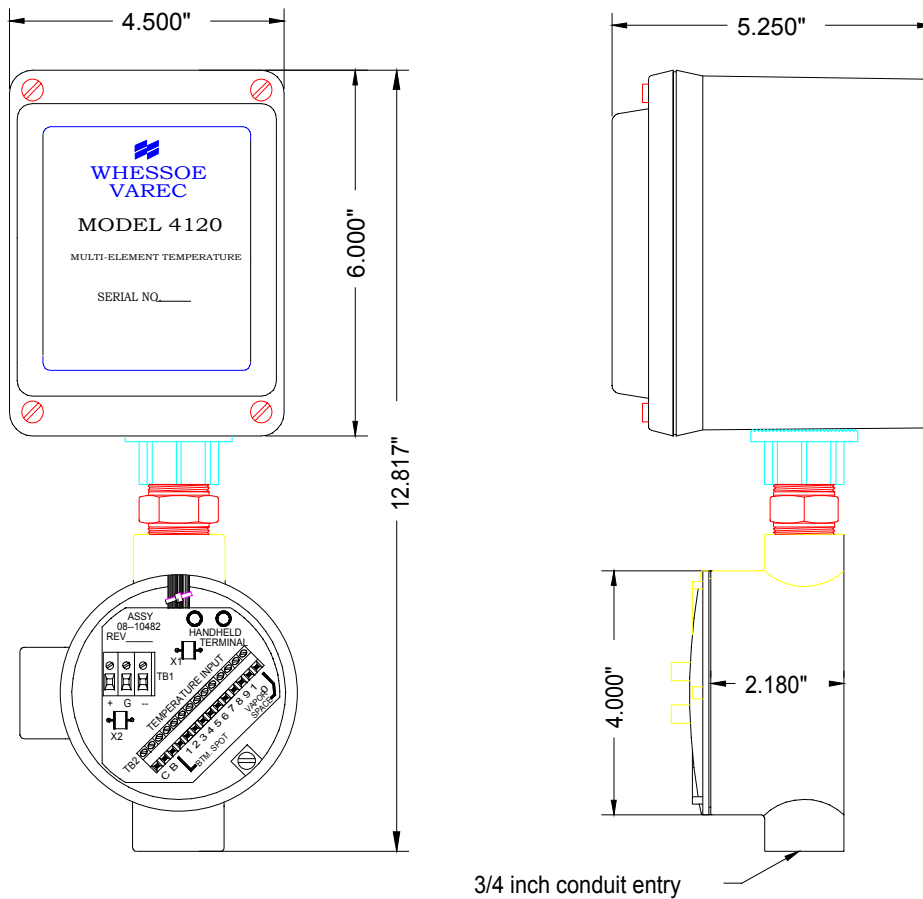

Figure 7 Model 4120 Dimensional Outline

Section 2 - Operation

The functional blocks of the Varec Model 4120 Multi-Element Temperature Transmitter are described below.

Temperature Configurations

The METT handles three temperature system configurations as follows.

API Averaging Bulb. API standard 2543 is used. An API averaging bulb has elements at 3', 5', 7', 10', 14', 20', 26', 32', and 40' for a 50' tank. For levels below 3', a spot probe is expected at the 2'. The standard specifies that non-merchantable product should be kept at least 1' below spot probe. The METT handles the bottom spot and a top spot for vapor space temperature measurement.

Non-API Averaging Bulb. This is a multiple-spot system which consists of up to 10 averaging RTD elements. The elements may be of non-standard lengths. The length of each element is configurable. Top and bottom spot temperatures are supported as above.

Multiple Spot. A multiple-spot system can consist of up to 12 3-wire RTDs. The height of each RTD is configurable. The first 11 can be averaged. The last spot is used as the top spot for vapor space temperature measurement.

Temperature Averaging

Averaging of the temperature depends on the type of temperature configuration being used. For averaging bulb configuration, the METT reads the longest immersed element and reports its temperature. The top probe is never used for averaging.

For multiple spot configuration, the METT reads all immersed elements and averages all readings. For simplicity, spot temperatures are averaged given equal weight to all immersed probes. The top probe is never used for averaging.

A host computer can read all temperature inputs via the HART protocol. Assuming the host knows the level and has the temperature configuration in its database, it can then calculate the average temperature. A host computer is also able to periodically write the current level and read back the average temperature. This method is preferred since the METT contains all the configuration information.

HART Communications Interface

The METT communicates to a host system via the HART communication protocol. The HART protocol allows the average temperature, temperature, and resistance to be read. It also allows the current level and configuration information to be sent to the METT.

**Varec
Handheld Terminal
Interface**

To support non-host configuration, the METT supports the Model 1200 Varec Handheld Interface. The Rosemount Model 268 may be used if available. The METT supports the ASCII interface in a similar manner to the Varec Model 4110 HART Level Encoder (LE). That is, it answers to two different HART addresses. The first address is its address for normal operation. The second address is the ASCII terminal address. The LE uses address 15 for this. The METT will use HART address 14 to allow for tandem operation with the LE in an MFT system.

To communicate with the METT using the Varec Handheld Interface, perform the following steps:

- 1. Make sure the Handheld Interface is not connected to the HART bus.
- 2. Turn the Handheld Interface off and then on. It will first go through its self-test, then try to communicate to a HART sensor at address 0. It will fail and display a warning message, "Xmtr/268 not in communication".
- 3. Press F2 to select multi-drop mode.
- 4. Press F2 to select the address to communicate to.
- 5. Press F2 twice to select address 14 and press F4 to start communication.
- 6. The METT will clear the screen and place the cursor at the upper left corner.
- 7. Pressing any key causes the METT to display the version number and ask if you want display or alter mode. Press 'D' followed by F4 for display mode or 'A' followed by F4 to select alter mode.
- 8. The F1 – F4 function keys have pre-defined functions. F1 is up, F2 is down, F3 is modify/backspace, and F4 is the enter key. The 'Previous Function' key can be used to abort modification of a variable or go up a menu level.

It is important to note that modifications done in Alter Mode do not take effect unless 'Exit and Save' is selected. This will cause the modifications to be saved to EEPROM and used. If you disconnect the Handheld Interface or select the 'Quit' command, any modifications that were made will be lost.

The menu interface is organized in a multi-level menu structure starting with the Main Menu.

Main Menu	Description
Average Temperature ¹	Average Temperature. Only valid if host, such as MFT, has been writing the level to the METT.
Level ¹	Last level written to METT. This can be manually entered to observe the effect of different levels.
Config Menu	Contains METT configuration menu items. See table below.
Diagnostic Menu ¹	Contains METT diagnostic menu items. See table below.
Exit and Save ²	Must be used to exit the Alter Mode if configuration data modified are to be entered.
Quit/Exit	Used to quit Alter Mode without saving. Also displayed as Exit in display mode.

Configuration Menu	Description
HART Address	METT's short address on HART bus. Set to 5 to use with MFT. Address 14 is reserved for Handheld Interface dumb terminal mode. (0-13 and 15 are valid)
Serial Number	Used for long address in multi-drop HART. Usually set at the factory. If problems communicating, try setting to same as HART address above.
Temp Units	Temperature units used for display. Use F2/F3 keys select.
Level Units	Level units used for display. Use F2/F3 keys to select.
Damping Value	Amount of damping. (0-16 is valid. 0 is minimal damping, 16 is maximum damping)
Noise Reject	Type of noise rejection. 50 Hz/60 Hz are valid. Use F2/F3 keys to select.
Temp Type: API Avg Bulb/Avg Bulb/Multi-Spot	Type of temperature system connected. API Avg Bulb/Avg Bulb/Multi-Spot are valid. Use F2/F3 keys to select.
Temp Element Type	Type of temperature element used. Can be copper or platinum. Use F2/F3 keys to select.
Bottom Probe Type None/Installed	Indicates if bottom probe is installed. Use F2/F3 keys to select.
Bottom Probe Height	Height of installed bottom probe.
Top Probe Type: None/ Installed	Indicates if top probe is installed. Use F2/F3 keys to select.
Top Probe Height	Height of top probe.
Temp Elements	Number of temperature elements attached. (1 - 10 is valid)
Element 1 Height	Height/Length of element. The heights are ignored and over-written if API average bulb is configured.
Element 2 Height	.
Element 3 Height	.
Element 4 Height	.
Element 5 Height	.
Element 6 Height	.
Element 7 Height	.
Element 8 Height	.
Element 9 Height	.
Element 10 Height	.
HART Variable 1 Type	Parameter to be returned as the first HART PV. Use F2/F3 to select. No configuration required if used with Varec's MFT.
HART Variable 2 Type	Same as above for the second HART PV.
HART Variable 3 Type	Same as above for the third HART PV.
HART Variable 4 Type	Same as above for the fourth HART PV.

Diagnostics Menu	Description
Bad EEPROM ³	EEPROM holding the configuration data could not be written to.
Bad EE Cksum ³	EEPROM configuration data's checksum is bad. Review all configuration data and perform an Exit and Save.
Bad RAM ³	RAM chip is bad.
Bad EPROM ³	Program memory is bad.
HART Polls ³	Number of HART polls received since power-up/new configuration write. (0-65535 and resets to 0 after full value)
HART Errors ³	Number of HART communication errors encountered since power-up/new configuration write. (0-65535 and resets to 0 after full value)
Bottom Temperature	Temperature at bottom probe
Temperature 1	Temperature at probe number 1
Temperature 2	Temperature at probe number 2
Temperature 3	Temperature at probe number 3
Temperature 4	Temperature at probe number 4
Temperature 5	Temperature at probe number 5
Temperature 6	Temperature at probe number 6
Temperature 7	Temperature at probe number 7
Temperature 8	Temperature at probe number 8
Temperature 9	Temperature at probe number 9
Temperature 10	Temperature at probe number 10
Top Temperature	Temperature at top probe.

¹ Only displayed if in Display Mode

² Only displayed if in Alter Mode

³ Only displayed if TRUE

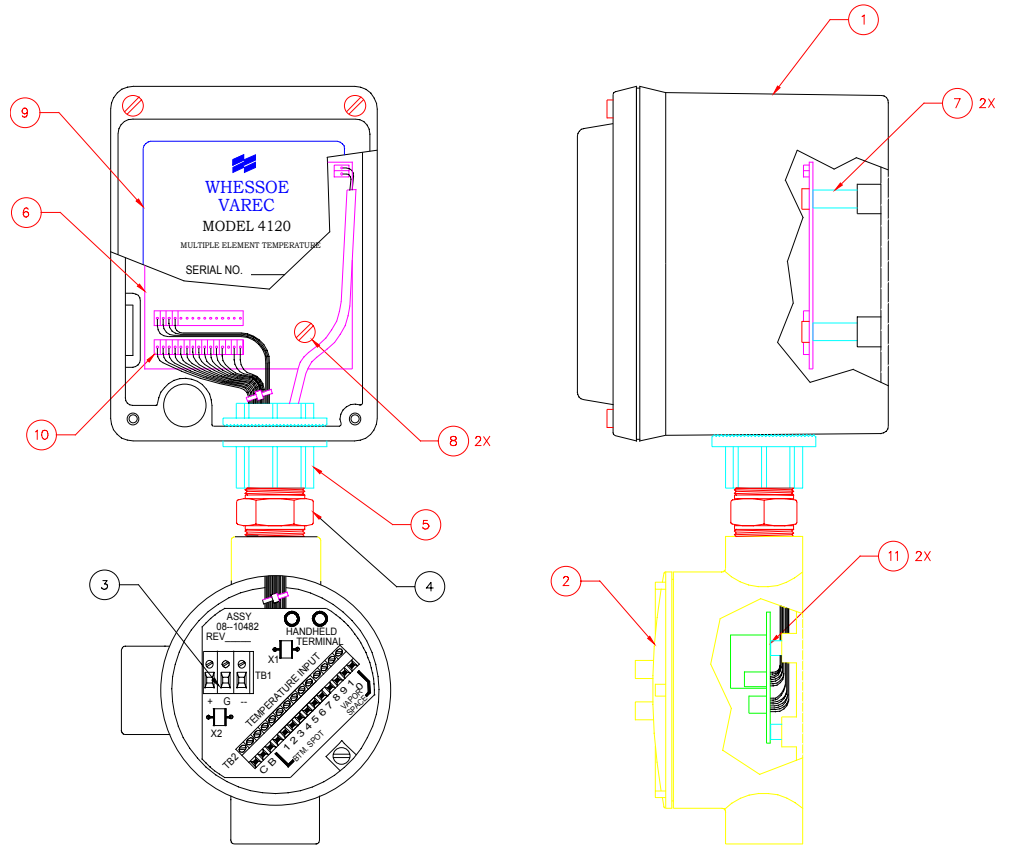

Figure 8 Model 4120 Component Identification

Item	Description	Part Number
1	NEMA 4X Enclosure	15-10727
2	Conduit Box	P109-18-014
3	METT Terminal PCB Avg. Bulb	08-10482
Not shown	METT Terminal PCB RTD	08-10747
4	Nipple Assembly	
5	Conduit Entry	P109-16-009
6	METT CPU PCB	08-10494
7	Standoff	P102-21-085
8	Screw 10-32	P031-06-1805
9	Label	varies
10	4120 Harness Assembly	02-10726
11	Screw 6-32	P31-824

Section 3 - Specifications and Reference Data

Specifications and Physical	The following specifications apply to the Varec Model 4120 Multi-Element Temperature Transmitter assembly over the operating temperature range.	
Functional	RTD Inputs Supported Copper and	100 Ohm Copper, 100 Ohm Platinum Characterized 100 Ohm Platinum (DIN)
	Input Voltage	15 to 65 VDC
	Operating Current	4 mA Constant Current
	Accuracy	+/- 0.5 oF (+/- 0.25 oC)
Hazardous Location Approvals	Designed to meet FM, CSA, and CENELEC intrinsically safe approvals for Class 1, Division 1 Groups B and C. (Consult factory for approval status.)	
Environmental	Operating Temperature	-40 oC to +85 oC
	Storage Temperature	-40 oC to +85 oC
	Transient Lightning	Meets ANSI/IEEE C62.41
	Humidity	0 to 100%
	Enclosure	NEMA 4X, Fiber Reinforced Resin
Performance	Accuracy, repeatability and sensitivity per American Petroleum Institute Manual of Petroleum Measurement Standards, Chapter 7, Section 7.4, fourth draft, December 3, 1990.	
Physical	Shipping Weight	6 lb. (3 kg)

Model Options

Model	Description			
4120	Multi-Element Temperature Transmitter			
	Code	Bulb Type		
	AB	Averaging Bulb		
	MS*	Multiple Spot Bulb		
		Code	Bulb Type	
		HA	HART	
		AT*	ATT - For use with Varec Model 400	
			Code	Approvals
			00	No Approval
			FM	Factory Mutual (FM)
			CS	Canadian Standard Association (CSA)
			CE	CENELEC
↓	↓	↓	↓	
4120	AB	HA	00	<i>Sample Ordering No: Multi-Element Temperature Transmitter with Averaging Bulb, HART Bus, and No Approvals</i>
* Consult Factory				

Section 4 - MFT/HIU and TankView Support for the METT

MFT/HIU Support

Model 4100 Multi Function Transmitter (MFT) and Model 4200 Hydrostatic Interface Unit (HIU) versions 1.6 and above include specific support for the METT.

- The MFT allows setting of the METT's HART address. It will expect it to be at address 5. This is the same address as the Rosemount 3044.
- A temperature selection of METT must be specified to the MFT under TEMP TYPE item located in the Sensor Configuration menu.
- If METT is the temperature sensor, the MFT periodically writes the level to it and reads the average temperature from it. Additionally, the MFT also reads all 12 temperature values from the METT and map those values into its MODBUS register. This allows a host computer to read all 12 values.
- The MFT does not duplicate all the configuration menus of the METT. The MFT expects the METT to have been configured for the desired temperature system .

TankView Support

The current TankView support for the METT is minimal. It basically allows the METT temperature type to be entered to tell the MFT the type of temperature device it is connected to.

Section 5 - HART Protocol Implementation

This section describes the HART implementation details for the METT. HART devices can return up to four dynamic variables with a single read. The METT has many more variables. HART devices have a mechanism that allows internal transmitter variables to be mapped to dynamic variables. Dynamic variables can be read via Commands 1 and 3 and are sometimes referred to as process variables (PVs). Command 33 allows reading of the transmitter variables directly by specifying their ID.

Transmitter Variables

The METT has the following transmitter variables available.

Transmitter Variable ID	Description
1	Average Temperature
2	Level
10 – 21	Temperature 1 – Temperature 12 (1 is bottom, 12 is top)
50 – 61	Resistance 1 – Resistance 12 (1 is bottom, 12 is top)

Standard HART Commands

The METT supports the following standard HART commands. Refer to the HART documentation for details on request and reply data.

HART Command	Description
1	Read primary variable
3	Read all dynamic variables
6	Write poll address
12	Read message
13	Read tag, descriptor, date
14	Read primary variable sensor information
15	Read primary variable output information
16	Read final assembly number
17	Write message
18	Write tag, descriptor, date
19	Write final assembly
33	Read transmitter variables
34	Write primary variable damping
38	Reset configuration changed flat
39	EEPROM Control
44	Write primary variable units
48	Read additional Transmitter Status
50	Read dynamic variable assignments
51	Assign transmitter variables to dynamic variables
53	Write transmitter variable units
54	Read transmitter variable information
55	Write transmitter variable damping
59	Write number of response preambles
122	Write device ID number
253	ASCII exchange command

METT Device Specific HART Commands

The following METT device specific HART commands allow the level to be written and the configuration information to be read and written.

HART Command #	Description
130	Write level
131	Read temperature configuration
132	Write temperature configuration
133	Read temperature element height
134	Write temperature element height

Each command is defined along with the expected request and reply data.

Parameter Name	Values
TempType	0 = API Averaging Bulb, 1 = Averaging Bulb, 2 = Multiple Spot
TempElemType	0 = Copper, 1 = Platinum
BotProbeType	0 = Not Installed, 1 = Installed
NoiseRejectType	0 = 60 Hz, 1 = 50 Hz
TempElements	1 - 10 is valid

Command 130 - Write Level
REQUEST DATA

[0-3] = Level in IEEE format

REPLY DATA

[0-3] = Level in IEEE format

Command 131 - Read Temperature Configuration
REQUEST DATA

NONE

REPLY DATA

[0] = TempType
 [1] = TempElemType
 [2] = TempElements
 [3] = BotProbeType
 [4] = NoiseRejectType

Command 132 - Write Temperature Configuration
REQUEST DATA

[0] = TempType
 [1] = TempElemType
 [2] = TempElements
 [3] = BotProbeType
 [4] = NoiseRejectType

REPLY DATA

[0] = TempType
 [1] = TempElemType
 [2] = TempElements
 [3] = BotProbeType
 [4] = NoiseRejectType

**Command 133 - Read
Temperature Element
Height****REQUEST DATA**

[0] = Element number, 0 - 11 is valid

REPLY DATA

[0] = Element number

[1] = Units Code

[2-5] = Element Height in IEEE format

**Command 134 - Write
Temperature Element
Height****REQUEST DATA**

[0] = Element number, 0 - 11 is valid

[1] = Units Code

[2-5] = Element Height in IEEE format

REPLY DATA

[0] = Element number

[1] = Units Code

[2-5] = Element Height in IEEE format

Your official representative



www.varec.com