



White Paper

June 24, 2009

## Stilling Well Recommendations

*This document describes general requirements for stilling wells used for radar tank gauging applications.*

# Contents

- Contents..... 2**
- Executive Summary ..... 3**
- Stilling Well Requirements ..... 4**
  - Minimum diameter ..... 4
  - Support of pipe ..... 5
  - Guiding of pipe..... 5
  - Lower/Bottom end..... 7
  - Perforations vs. slotted ..... 7
  - API recommendations ..... 8
  - Location..... 8
  - Grounding ..... 8
  - Vapor seals..... 9
  - Hand dipping..... 9
  - Manual sampling..... 10
  - Material..... 10
  - Installation of coaxial stilling wells for ATG applications..... 10
  - Welding of stilling wells and tanks..... 10
  - Specific ATG requirements ..... 11
- Credits..... 12**
  - About Varec ..... 12
  - References ..... 12
- Copyright ..... 13**

## Executive Summary

Tanks, particularly floating roof tanks, are frequently fitted with stand pipes, stilling wells or guide pipes. The naming of these theoretical 'identical' pipes or wells can all be traced back to the original intent at the time of installation:

- **Stilling well** – originally installed to provide a 'quiet' and stable surface for manual or automatic tank level measurement
- **Guide pipe** – relatively large size stilling well, typically used in external floating roof tanks to provide an anti-rotation device, which facilitates hand dipping and sampling at the same time – with a minimum of (floating) roof penetrations
- **Stand pipe** – vertical column – used to provide a stable gauging platform

Through the evolution of tank design, we have now reached an 'industry standard' for tank construction and the exact differences between the various versions are difficult to distinguish. For the remainder of this document, the term 'stilling well' will be used for all forms of technical solutions.

This paper has tried to create a readable overview – and hence, not all forms of special developments over the last 50 years have been included.

## Stilling Well Requirements

In the relevant API documents (see references), you can find detailed information on stilling wells. The primary reasons for having a stilling well are:

- Provides a stable gauge reference point (limits vertical movement)
- Provides a relatively 'quiet' product surface during filling and emptying of the tank, especially if 'swirl' exists, and is required for mechanical types of automatic tank gauges (ATG's) or for tanks in which products with a very low read vapor pressure are stored, such as LPGs.
- Prevents floating roof rotation and allows access to the stored liquid product at the same time

Note: With the invention of radar for tank gauging, the stilling well is increasingly appreciated. For example, in LPG applications, the stilling well acts as a 'wave guide' for the radar energy. In these applications the well helps to bundle the emitted signal and minimize the signal loss – a must on products with an intrinsically low product reflectivity (caused by a low dielectric constant) and surface phenomena like 'boiling off' and 'vapor mist'.

### Minimum diameter

API suggests a minimum diameter of 8". In general, 8" should be sufficient, but for very large external floating roof tanks, larger diameters of up to 12" should be considered. Diameters above 12" are not particularly useful. For relatively small tanks (maximum height 30 ft), 6" diameters can be considered. For horizontal cylindrical (bullet) tanks (maximum diameter 13 ft), a stilling well of 2" diameter can be considered.

**A bad example of a radar gauge/stilling well junction**



It is advised to make the whole stilling well the same diameter, especially in the case when a radar level gauge is used. Changes in pipe diameter change the speed of radar and, thus, the absolute accuracy of a system. This is less critical with other gauge technologies, such as servo gauges.

For larger sized stilling wells (8" and up) the use of a reducer can be considered, in which case it is advised to make the transition piece long enough (refer to the material requirements).

### Support of pipe

Preferably, the stilling well should be supported out of the tank bottom. In areas where the ground on which the tank sits is very unstable, it is suggested to support the stilling well out of the lowest part of the tank shell (less than 1 foot from the tank bottom as shown).



For tank floor support, a simple tripod is sufficient. For tank shell support, it is important that a certain amount of tank 'bulging' (due to hydrostatic tank deformation) can be tolerated without extreme mechanical stress exerted on the tank shell itself.

### Guiding of pipe

The top end of the stilling well should be properly guided and allow for vertical movement of the tank shell and tank roof in respect to the stilling well. Normally, a construction with three centering bolts is considered to be enough. The bolts can be adjusted for reducing horizontal and vertical tolerances.

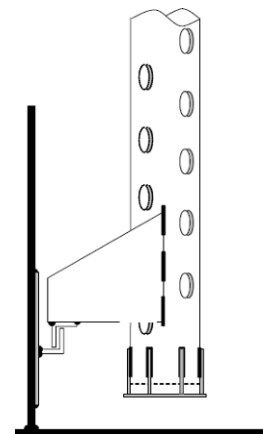

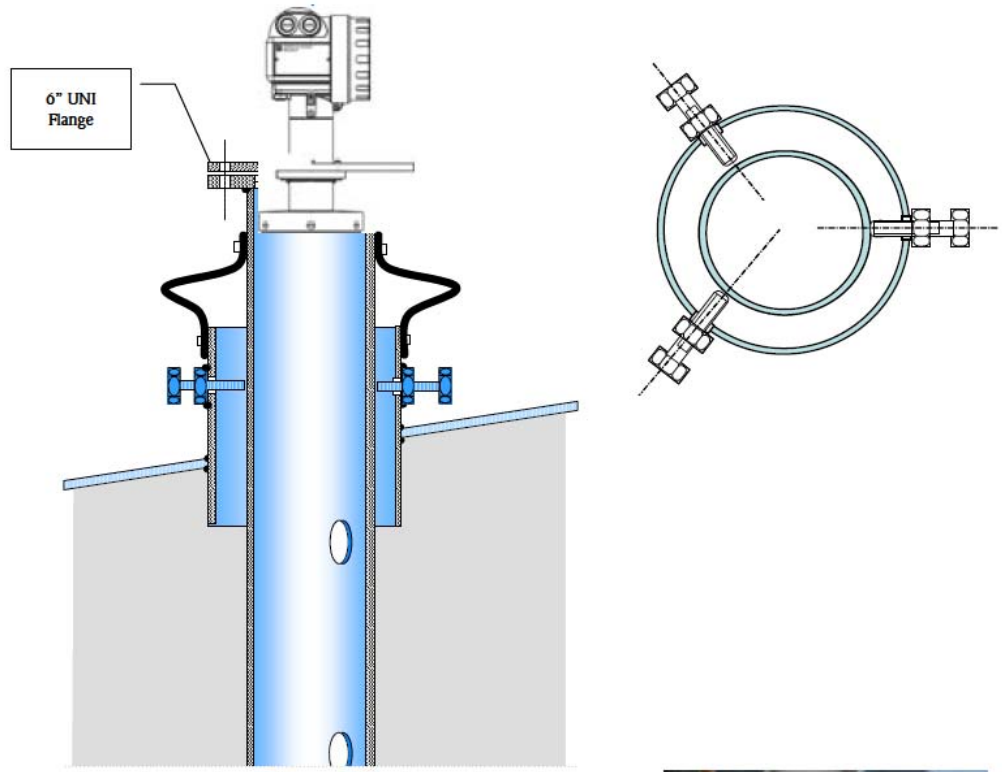

Left to right: 1) 6" UNI Flange, 2) Centering of stilling well 3) Good example. Stilling well can move vertically free from the platform. 4) Bad example. Stilling well is fixed to the platform.

### Lower/Bottom end

The lower end of the stilling well should extend to within 12" of the tank bottom.

### Perforations vs. slotted

Slots or perforations are a must on any stilling well used for level gauging, independent of whether it is by manual or automatic means.

Typical hydrocarbons show an average thermal expansion coefficient of 0.1% every °C. Most hydrocarbons can vary largely by composition.

*Top – A bad example. Slots are too big; made with a torch. They are affecting the radar signals and absolute accuracy. Servo is not influenced. Bottom - A good example as the grinded slots are not oversized.*

If a stilling well is not slotted or perforated, the product in the stilling well will be pushed in from the bottom. This may include water or sediment, which is not representative of the rest of the tank. The product pushed in can have a different temperature and composition as well and, therefore, a different base density and observed density. As a result, the product column inside the stilling well, with a different actual density than the average product in the tank, can show a different level per the physical law called 'communication vessels'. A difference as small as 0.1% in density (0.8 kg/m<sup>3</sup> on a typical product of 800 kg/m<sup>3</sup>) in a tank containing 33 ft of product will result in a level difference of 0.5".



Note: It is assumed that the top of the stilling well is ‘open’ and not hermetically sealed. The opening can be inside the tank and below the roof provided the highest hole or perforation is well above the maximum safe oil level for the tank. Failure to follow these guidelines can lead to serious level errors and, in worst case situations, even to overfills and product spillage.

### **API recommendations**

In the relevant API standard (Ch. 3.1A), two rows of overlapping slots or holes located on opposite sides of the pipe are recommended. This recommendation is slightly overdone and current insights are that this requirement can be reduced, allowing for attractive cost reductions. If radar is considered, the total size of slots can not only be an issue for the radar measurement, but also for the resulting forces internally in the pipe, causing the pipe to bend. In addition, the material burrs produced when making the slots are a disadvantage for radar gauging.

For most hydrocarbon applications, it is proposed to have a double row of 1” to 1½” holes on opposite sides of the pipe, with the holes staggered on both sides with a pitch of approximately 2 ft. It is also suggested to let the holes be radial on the center of the tank (minimizing product flow through the pipe). All holes should be properly de-burred.

For very light products, like LPGs stored in bullet tanks with a 2” to 3” stilling well, the hole diameter can even be further reduced to 0.25” to 0.5”.

### **Location**

API recommends that the center line of the stilling well be approximately 18” to 30” from the tank shell in order to minimize temperature effects from the tank shell.

### **Grounding**

It is essential that the stilling well is extremely well grounded to the tank potential. It is advised to have at least two braided wires between the tank shell and stilling well, preferably one at the bottom and one on the tank roof.

The braided wires should be at least 2" x 0.25" mm and preferably welded or connected with shark rings. A simple nut and bolt is definitely not enough, as paint and rust will prevent proper galvanic contact.

### Vapor seals

A vapor seal is recommended in all cases in order to minimize vapor emissions. A simple rubber boot clamped on the well and fixed to the roof is normally sufficient.

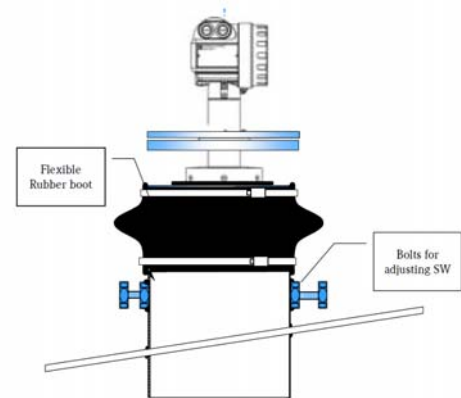

### Hand dipping

If the stilling well is used for both automatic tank gauging and hand dipping, it is essential that access is provided. Opening and closing should be simple and uncomplicated without the need for special tools or without parts that can become separated and are likely to be dropped, damaged or lost.

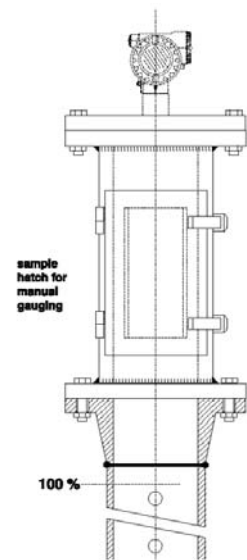

*Good results are obtained using so called 'hinged door' constructions. A hinged door access can be used for both servo and radar technologies.*

For installations where vertical visual access into the tank is required, it is possible to use a 'swivel' approach, although this type of appendage is only applicable for radar gauging.

For accurate hand dipping in custody transfer applications, it is recommended to have the reference height of the dip location properly identified next to the dip hatch. Please make sure that there is no

diameter change or gaps in the seal between stilling well and dip hatch in the case where a radar gauge is used. This is not an issue for other gauge technologies, such as servo gauges.

### Manual sampling

The hatch should be large enough to allow easy access and retrieval of a sampling bottle.

### Material

Materials used should be compatible with the product stored. For smaller tanks and small diameter stilling wells (less than 4"), stainless steel can be considered, as it allows for thinner walls and does not require any formal coating or corrosion protection.

### Installation of coaxial stilling wells for ATG applications

Note: API is aware that, for some radar applications, it is advised to insert a secondary stilling well in the originally installed stilling well. This may be due to excessive size of the slots, corrosion, reducers welded to pipe (above or below roof) or the necessity to install an average temperature sensor on the same stilling well.

This issue was discussed in several API workgroup meetings and future standards will reflect the now current joint opinion: Stilling wells used for manual sampling, i.e. stilling wells that are not only used for automatic level gauging, but where product samples are taken out for chemical, physical and/or composition analysis, should not be equipped to have a secondary (coaxial) stilling well inside. It is thought that this would have a negative influence on how representative the product sampled is compared to the average product in the tank.

### Welding of stilling wells and tanks

Weld the stilling well segments only on the outside. Inside welding slags will reflect radar signals and will have an influence on the signal to noise ratio and speed of the radar signal. It is advised to remove any instruments with electronics before welding, as you may damage the electronics of the instrument.

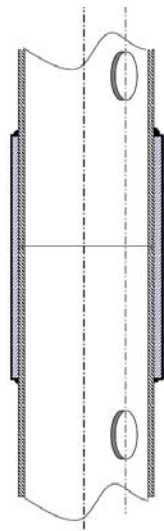

### Specific ATG requirements

Depending on the application and type of selected or preferred automatic tank gauging equipment, the following mechanical design issues should be evaluated:

**Reducers** - For radar applications, the slope of the reducer should be kept reasonable. 6" per 1" diameter change is considered to be acceptable (i.e. an 8" to 6" reducer needs to be 12" long. a 12" to 8" requires an 18" long reducer). In general, the longer the transition the better.

**Safety or isolation valves** - For applications requiring safety or isolation valves, such as on pressurized applications with products like LPGs, it is a must to select the proper valve size. The valve should be full bore and the inside diameter should match the stilling well. Keep the seal as thin as possible to avoid radar noise.

**Perforations** - Should be minimized in combination with radar – diameter of holes should be kept well below 1/10th diameter of the stilling well. Do not use torches to burn them in, but grind them to avoid slag and, thus, false radar reflections on the inside of the stilling well.

## Credits

### About Varec

*Varec, Inc. delivers measurement, control and automation solutions and professional services for most major oil companies, defense organizations and airlines worldwide. Varec's FuelsManager® software applications and hardware products provide local level management and enterprise visibility of liquid petroleum assets at bulk storage facilities, marketing terminals, refineries, petrochemical plants and military fuel facilities.*

### References

1. Manual of Petroleum Measurement Standards – Chapter 3 – Tank Gauging – Section 1A – Standard Practice for the Manual Gauging of Petroleum and Petroleum Products (1st edition, Dec. 1994)
2. Manual of Petroleum Measurement Standards – Chapter 3 – Tank Gauging – Section 1B – Standard Practice for Level Measurement of Liquid Hydrocarbons in Stationary Tanks by Automatic Tank Gauging (2nd edition, June 2001)

## Copyright

***© Copyright 2009 Varec, Inc. All rights reserved. No part of this publication may be reproduced or transmitted in any form or for any purpose without the express permission of Varec, Inc. The information contained herein may be changed without prior notice. Some software products marketed by Varec, Inc. and its distributors contain proprietary software components of other software vendors.***

***All other product and service names mentioned are the trademarks of their respective companies. Data contained in this document is for informational purposes only.***

***These materials are subject to change without notice. These materials are provided by Varec, Inc. for informational purposes only, without representation or warranty of any kind and Varec, Inc. shall not be liable for errors or omissions with respect to the materials. The only warranties for Varec, Inc. products and services are those that are set forth in the express warranty statements accompanying such products and services, if any. Nothing herein should be construed as constituting an additional warranty.***