

# 4200 Multi-Function Transmitter

For tank side display and electronic transmission of data captured from inventory tank gauges

Varec®



FuelsManager®  
Compatibility



## Benefits

- Executes complete HTG or hybrid HTG and standard tank calculations
- Microprocessor controlled communications to host and slave devices
- Tank database resident within 4200 MFT, including API and strap tables
- Supports up to three precision HART® HTG pressure transmitters and other HART® instruments
- Mark/Space and Modbus communication modules meet most user requirements
- Intrinsically safe barrier for HART® power and communications
- FM & CSA approved for use in hazardous areas
- Modular, plug-in design with optional built-in window and LCD display.

## Application

The 4200 Multi-Function Transmitter (MFT) provides extensive primary sensor support, while also executing complex hydrostatic or hybrid hydrostatic tank calculations.

Multiple process variables are supported through the local display, including values for level, temperature, volume, mass, density, alarms and flow. The 4200 MFT can then calculate and display the required tank gauging information to allow your operator to manage his inventory safely and effectively.

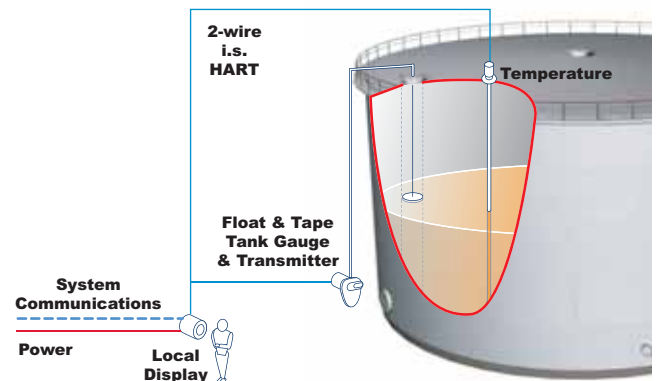

## Function and System Design

The Model 4200 Multi-Function Transmitter (MFT) is specifically designed for inventory management applications. The 4200 MFT fully supports hydrostatic and hybrid tank gauging systems and interfaces when connected to various types of devices, such as level gauges or pressure and temperature transmitters.

### Operation

The 4200 MFT collects measurement information by polling the HART® compatible devices, such as the HART® Level Encoder, over the 2-wire intrinsically safe HART® bus. The 4200 MFT is able to provide power and communicate with up to eight HART® devices. The 4200 MFT processes and transmits this information to a host computer, MODBUS® master or intermediary device over a field communications bus.

Two field communication options are available, Varec Mark/Space and EIA-485. The 4200 MFT supports 2-wire EIA-485 communications. The Mark/Space interface is compatible with existing Varec Mark/Space products, including the Varec 1800 and 1900

transmitters and is also capable of being configured to emulate these Varec transmitters.

The MODBUS® protocol is supported directly over the EIA-485 interface when connected to a Model 6850 Field Interface Unit. MODBUS® is also supported with the Mark/Space field bus through a 8130 Remote Terminal Unit (RTU).

The 4200 MFT uses measurement information from the variety of input devices to calculate product parameters. The HIU supports traditional tank calculations, as well as hydrostatic (level and density calculated using measurements from tank pressure sensors) and hybrid (level obtained from a level encoder and density calculated using level and pressure measurements) tank calculations.

The 4200 MFT can be configured to identify tank alarm conditions. Alarm and/or caution conditions can be reported to a host over the field communications bus or displayed on the optional local display.

## Installation Guidelines

The 4200 MFT is typically attached to the gauge pipe extension at the tank side. It can also be mounted up to 1000 ft (300 m) away. A mounting bracket assembly, included with the 4200 MFT can be used for most installations.

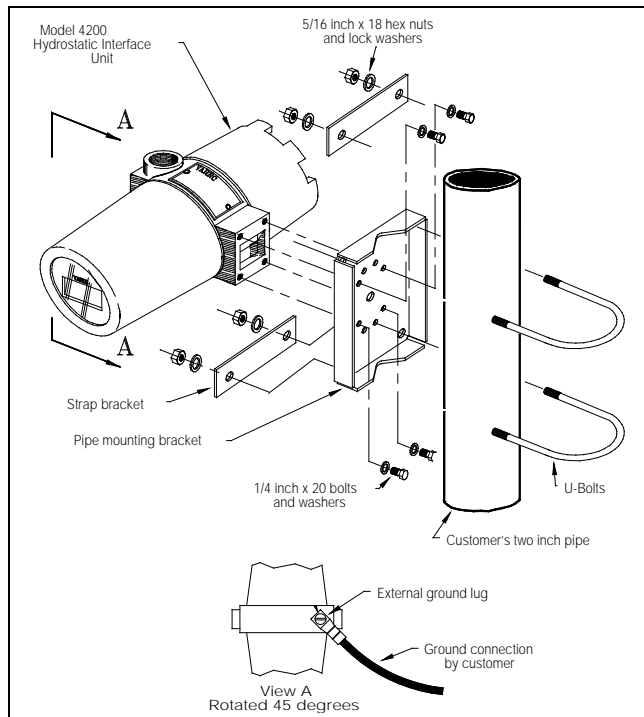

The 4200 MFT mounting bracket kit

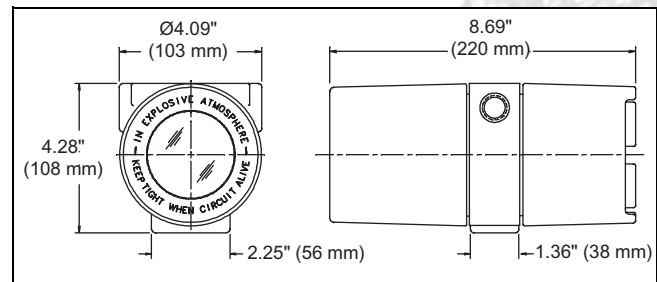

4200 MFT Dimensions

### Grounding the Equipment

A connection from the ground lug to earth ground must be made before any other wiring connections are made. For adequate/proper operation of the 4200 MFT lightning arrester, a ground strap must be attached to the 4200 MFT. Grounding through mounting kits or pipe coupling is not recommended.

Properly seal all ports to prevent moisture or other contamination from entering the wiring compartment.

## Input and Output

### Wiring the 4200 MFT

Wiring to the 4200 MFT consists of connecting power, host communication, RTD input and ground connection. The procedure used to wire the 4200 MFT to the host computer depends on the type of host interface option ordered.

Terminal	Description
1	Common (B-)
2	B+ input
3	Mark/EIA-485 "+"
4	Space/EIA-485 "-"
5	Status 1 Input
6	Status 2 Input
7	4-20 mA "+"
8	4-20 mA "-"
9	RTD : C-Lead
10	RTD : B-Lead
11	RTD : A-Lead
12	Status COM.

### Input Power

The 4200 MFT operates on a 22-65 volts DC power source.

**Note!** The operation manual indicates the resistivity (in Ohms/1,000 ft) of the wire commonly used for power distribu-

tion and also a formula for calculating the maximum permitted power wiring resistivity for a given distance and number of units.

### Temperature RTD Input

The 4200 MFT measures temperature directly using a high accuracy 16-bit analog to digital converter. 3-wire Copper, Platinum RTD, 4-20 mA or HART® compatible temperature devices are supported.

### 4-20 mA Input

The 4-20 mA device interface can be used for a variety of measurement functions. When used with a secondary 4-20 mA level device, the interface can be used to check level measurements or calculations. A water interface sensor is available with 4-20 mA output.

### Digital Status Inputs

Two dry contact closure digital status inputs are available. These inputs are isolated from earth and signal ground and are provided with lightning and transient protection.

### Field Communications

For integration with your tank gauging instruments and inventory system, the following inputs and outputs are available:

- MODBUS Slave
- Mark/Space Wiring
- EIA-485 Wiring
- 4200 MFT HART® Bus Wiring

## Configuration

The 4200 MFT must be configured for the specific tank, attached sensors and host interface. All configuration is performed using the Model 1200 Handheld Terminal (HHT) or a download from host computer software, such as FuelsManager. The 1200 HHT connects to the same HART® bus used to interconnect the other HART® devices; there are no switches or jumpers to configure.

**Note!** For the specific steps needed to configure the 4200 MFT, please see the Installation, Operation and Maintenance Manual.

## Accessories

### Spare Parts and Maintenance Kits

The 4200 MFT is designed and manufactured to provide accurate and reliable operation without an intensive maintenance schedule.

Varec can provide spare parts, maintenance kits, preventive maintenance advice, training and warranties. Please consult your Installation and maintenance manual or a representative for more details.

### 1200 Handheld Terminal

The 1200 Handheld Terminal (HHT) is a device used to support configuration of all Varec equipment with HART® and ATTI bus, such as:

- 4000 Advanced Technology Transmitter (ATT)
- 4040 ATTI Bus Display Unit (BDU)
- 4050 ATTI Bus Digital Input/Output Unit (BIU)
- 4110 HART® Level Encoder (HLE)
- 4120 Multi-Element Temperature Transmitter (METT)
- 4200 Multi-Function Transmitter (MFT)

The 1200 Handheld Terminal (HHT) can be connected at any point in the field communications loop using an interface cable with two "banana" plugs. The unit is light, easy to grip in one hand and provides a large supertwist graphics LCD display. All alpha keys are accessed through a single shift key. High speed communications ensure fast response and virtually eliminate "com error" messages.



The 1200 HHT is FM approved for use in intrinsically safe areas.

### Ordering the 1200 HHT

When ordering, please use the product designation "N1200". The 1200 HHT weighs 2lbs (0.9kg) and comes complete with a carrying case, strap, interface cable and three "AA" batteries.

## Technical Specifications

The following specifications apply to the 4200 MFT over the normal (ambient) operating temperature range.

### Physical

<b>Enclosure</b>	Explosion proof die-cast epoxy coated aluminum Rated IP65 (NEMA 4), NEMA 7
<b>Bolts</b>	Plated carbon steel per ASTM A449, Grade 2
<b>Conduit entries</b>	Integrated junction box provides 2x 1/2" NPT

### Environmental

<b>Operating temperature</b>	-40 °F and +185 °F (-40 °C and +85 °C)
<b>Operating humidity</b>	0 to 95% relative humidity non-condensing
<b>Transient lightning protection</b>	ANSI/IEEE C62.41
<b>EMI</b>	SAMA 33.1C
<b>Vibration shock</b>	SAMA PMC 31.1

### Power

<b>Power requirements</b>	22 to 65 V dc (with internal fuse)
<b>Efficiency</b>	85% minimum
<b>Earth isolation</b>	2500 VRMS
<b>Short circuit protection</b>	Infinite duration (any/all outputs)
<b>Earth isolation</b>	2500 VRMS

### RTD Temperature Measurement

<b>RTD type</b>	100 Ohm, Platinum DIN or Copper
<b>Measure type</b>	3-wire
<b>Wiring resistance</b>	20 Ohm per lead, max. leads matched to +/- 0.1 Ohm
<b>Accuracy at ambient</b>	+/- 0.2 °F (0.02 °C)
<b>Display/data units</b>	Fahrenheit or Celsius

### 4 - 20 mA Measurement

<b>Termination resistance</b>	20 Ohm
<b>Source voltage</b>	18 - 25 V dc

<b>Current limit</b>	25 mA
<b>Calibration accuracy</b>	+/- 0.01 mA
<b>Sensor calibration</b>	1200 Handheld Terminal
<b>Resolution</b>	0.005 mA

### LCD Display

<b>Non-destructive temperature range</b>	-40 °F to +185 °F (-40 °C to +85 °C)
<b>Normal operating temperature range</b>	-4°F to +158°F (-20 °C to +70 °C)
<b>Backlight supply</b>	5 V dc @ 40 mA
<b>Backlight "ON" time</b>	10 to 20 minutes
<b>Configurable display</b>	Level/ Temperature/ 4-20 mA/ Alarms/ Hydrostatic/ Hybrid Update Period

## Field Communications

### Mark / Space

<b>No. of units</b>	50+ (Depending on specifications; consult a Varec Engineer)
<b>Mode</b>	Low speed or high speed Mark/Space
<b>Cable</b>	Four (4) wire, twisted pairs

### EIA-485 MODBUS

<b>No. of units</b>	32
<b>Baud rate</b>	300, 600, 1,200, 2400, 4,800 or 9,600
<b>Cable</b>	Three (3) wire
<b>Distance</b>	4,000 feet (1,230 m)

### Digital Status

<b>Number of inputs</b>	2
<b>"ON" contact resistance</b>	500 Ohm maximum
<b>Earth isolation</b>	2500 VRMS

## Certifications & Approvals

<p>Factory Mutual (FM)  Explosion Proof Class I, Division 1, Groups C &amp; D  Dust-Ignition Proof Class II, III, Division 1, Groups E, F, G  Non-Incendive Class I, Division 2 Groups A, B, C, D  Suitable For Class II, III, Division 2 Groups F &amp; G  Intrinsically Safe For Class I, II, III;  Division 1 Groups A, B, C, D, E, F, G</p> <p>CSA  Class I Division 1 Groups C &amp; D;  Class II Division 1 Groups E,F,G;  ClassIII encl. Type 4 rated  (LR 40894-32)</p>
---

## Order Codes

### 4200 Multi-Function Transmitter

Field Communications Options	
1	Varec Mark/Space
2	EIA-485/MODBUS®
Approvals	
A	FM
B	CSA
0	For use in non-hazardous areas
Sensor Support Options	
1	Standard HART
2	4-Wire HART (7500 Series RTG)
<b>N4200 -</b>	Complete product designation

[www.varec.com](http://www.varec.com)

5834 Peachtree Corners East • Norcross, GA 30092  
Tel: +1 (770) 447-9202 • Toll Free: +1 (866) 698-2732 • Fax: +1 (770) 662-8939



If no official representative is listed here, please visit [www.varec.com](http://www.varec.com) to find your local representative. © Varec, Inc. All Rights Reserved. This document is for information purposes only. Varec, Inc. makes no warranties, express or implied, in this summary. The names of actual companies and products mentioned herein may be the trademarks of their respective owners.