

4110 HART Level Encoder

Precision encoding instrument for transmission of level measurement from mechanical float gauges



FuelsManager[®]
Compatibility



Features

- Universal connection – mounts to all standard float gauges
- Low maintenance – no gears, electrical brushes or alignment sensitive arrays – the precision disk assembly is the only moving part
- 2-wire intrinsically safe design
- Explosion proof NEMA Type 4 die cast enclosure with junction box
- Fully integrated terminal unit – allows complete configuration using a handheld device

Applications

The 4110 HART[®] Level Encoder (HLE) connects directly to a mechanical float and tape tank gauge. Liquid Level data from the float gauge is encoded and transmitted to a HART[®] Host device. The unit is fully compatible with industry standard PLC's and RTU's utilized in tank farms, refineries and terminals and is designed to communicate with these devices over a low voltage, intrinsically safe, HART[®] communications bus.

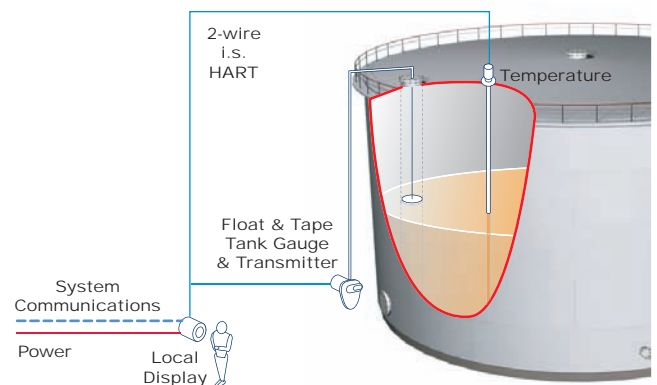

Function and System Design

The 4110 HART® Level Encoder (HLE), in conjunction with a HART® master, such as a 4200 MFT, provides a data acquisition and communications system for use in liquid level measurement applications. The 4110 HLE communicates the liquid level, which is measured by a mechanical float and tape tank gauge, such as the 2500 Automatic Tank Gauge (ATG). Any tank calculations needed are performed by the HART® master.

The 4110 HLE uses an incremental counting technique for determining liquid level. After an initial level is

determined as part of the calibration procedure, changes are determined through incremental increases or decreases detected by the 4110 HLE.

The unit has been tested by and is compatible with products manufactured by Armcom Control Systems and Allen Bradley Co. This enables users in a wide range of industries and in varying applications to benefit from the features of HART® communications and third-party products. Contact Varec for further details of these interfaces.

Installation Guidelines

The following information should be used as a guide only; please refer to the operation and maintenance manual for complete installation instructions. You are able to leave the tank in-service and the mechanical float gauge in place while you install and configure the 4110 HLE.

certain that the slot in the 4110 HLE drive coupling engages with the pin on the tape sheave of the mechanical float gauge.

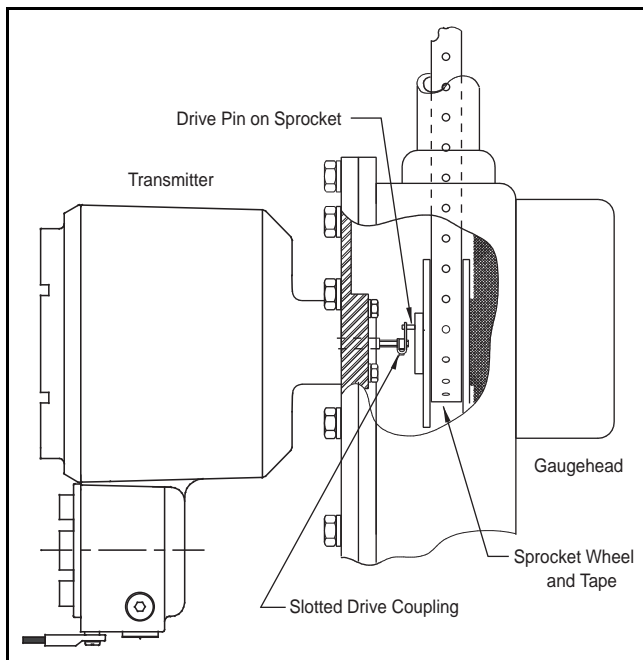

4110 HLE connected to a 2500 Automatic Tank Gauge (ATG)

Before the 4110 HLE is connected to a mechanical float gauge at the tank side, check the following:

1. The mechanical float gauge is operating correctly
2. There is sufficient space around the mechanical gauge to install the transmitter and accessories (such as conduit and cabling)
3. You have the correct transmitter/mechanical gauge adaptor if required
4. You have the correct field connections at the gauge-head ready to connect to the 4110 HLE (i.e. power, communications and temperature sensor wiring)

To mount the transmitter onto the gauges the back cover of the mechanical float gauge must first be removed. Mount the 4110 HLE in place of the access cap, making certain that the "TOP" of the 4110 HLE housing lines up with the top of the back cover. Make

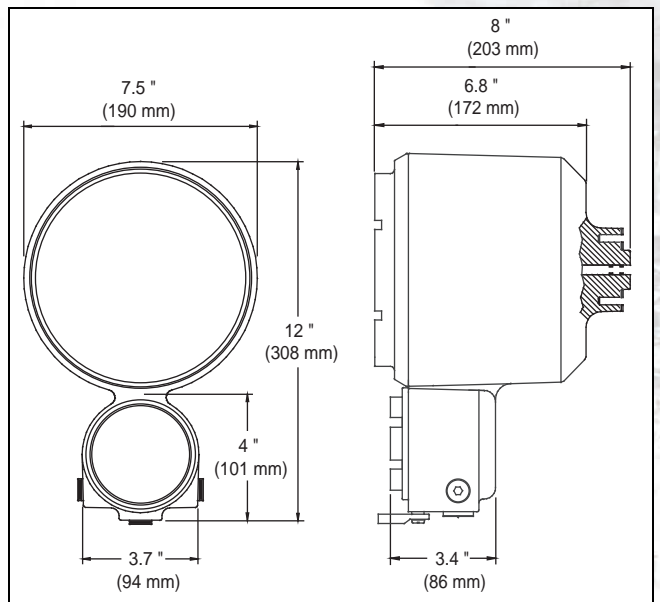

4110 HLE Dimensions

Configuration

Communications

The HART® Host collects measurement information by polling the 4110 HLE over a 2-wire intrinsically safe HART® bus and then transmits this information to a host computer, MODBUS™ master or intermediary device. Power to the 4110 HLE is provided by the HART® Host device and a battery backup is integrated into the device to provide continuous tracking of level measurement through power outages.

HART Bus Connection

The HART® Bus connection to the 4110 HLE is accomplished in the following manner:

- Run the two HART® bus wires into the 4110 HLE terminals through the conduit entry (NPT plugs).

- Connect the minus (-) to terminal one (1).
- Connect the plus (+) to terminal two (2).
- For intrinsically safe (I.S.) installations, connect the chassis ground of the 4110 HLE to the ground terminal of the HART® master device.

Configuration

The 4110 HLE can be configured by the HART® master, such as the 4200 Multi-Function Transmitter (MFT) or Varec handheld devices via the HART® bus terminal connections. The 4110 HART® LE cover may be removed without powering the encoder down when properly installed in an I.S. circuit. For complete instructions, please refer to the specific manuals for the instrumentation used within your tank gauging system.

Technical Specifications

The following specifications apply to the model 4110 HLE over the normal (ambient) operating temperature range.

System Design

Encoder	Incremental, infrared optical reflective
Encoder sensors	Two (2) fixed position, infrared
Gearing system	Stainless steel, direct drive

Performance

Accuracy	0.04" in (1.0 mm)
Encoder resolution	0.04" (1.0 mm)
Rotational speed	1,000 RPM maximum @ 100% accuracy without losing synchronization with the gauge.
Available ranges	0 to 128 ft (0 to 39 m)

Physical

Net weight	13 lbs (5.9 kg)
Shipping weight	16 lbs (7.25 kg)
Enclosure	Explosion proof die-cast epoxy coated aluminium Rated IP65 (NEMA 4)
Conduit entries	Integrated junction box provides 3 x ¾" or 3 x 2½" NPT (both sized plugs are provided)
O-rings seals	Dual o-rings on encoder shaft (Buna-N) Electronics & integral junction box covers (Buna-N)

Environmental

Operating temperature	-40 °F and +185 °F (-40 °C and +85 °C)
Operating humidity	0 to 95% relative humidity non-condensing
Transient lightning protection	ANSI/IEEE C62.41

Power

Power requirements	18 V _{dc} nominal 12.5 V _{dc} minimum 30 V _{dc} maximum
Operating voltage	8 mA nominal @ 18 Vdc (0.13 W)
Power supply	HART® master
Battery shelf life	Ten (10) years

Field Communications

Communications	Hart 5.0 digital compliant
Communications range	Maximum 1,000ft to 4,200 MFT

Certifications & Approvals

E-P/I.S. CSA Certified
Class I Division 1, Groups C & D;
Class II Division 1, Groups E,F,G;
ClassIII Enclosure Type 4 rated (LR 40894-33)

Factory Mutual (FM)
Explosion Proof
Class I, Division 1, Groups C & D
(FMRC 0X2A2.AE)

Accessories

Spare Parts and Maintenance Kits

The 4110 HLE is designed and manufactured to provide accurate and reliable operation without an intensive maintenance schedule.

Varec can provide spare parts, maintenance kits, preventive maintenance advice, training and warranties. Please consult your Installation and Maintenance Manual or a Varec representative for more details.

Transmitter Adapter Kits

The following kits include the necessary parts, including an adaptor bracket to allow the 4110 HLE to mount to other manufacturers' tank gauges.

Part #	Description
13-05956-102	Adapter kit for mounting to L&J 92514, 92020 and 92030 gauges
13-05956-202	Adapter kit for mounting to L&J 92006 and Whessoe Varec 2006, 2026 and 2036 gauges

Order Codes

4110 Hart Level Encoder

	Approvals	
	A	FM
B	CSA	
N4110	Complete product designation	



www.varec.com

Corporate Headquarters

5834 Peachtree Corners East
Norcross (Atlanta), GA 30092
USA
Tel: +1 (770) 447-9202
Toll Free: +1 (866) 698-2732
Fax: +1 (770) 662-8939

Houston

5151 San Felipe
Sage Plaza, Suite 1100
Houston, Texas 77056
USA
Tel: (281) 498-9202
Fax: (281) 498-0183

Asia Pacific

Level 8, 91 William St.
Melbourne
Victoria 3000
Australia
Tel: +61 3 8623 6400
Fax: +61 3 8623 6401

Europe

Suite 120, 94 London
Road
Headington, Oxford
Oxfordshire, OX3 9FN
United Kingdom
Tel: 0800 044 5704
Fax: 0844 544 1874

Authorised Representative

If no official representative is listed here, please visit www.varec.com to find your local representative.

2010 © Varec, Inc. All Rights Reserved. This document is for information purposes only. Varec, Inc. makes no warranties, express or implied, in this summary. The names of actual companies and products mentioned herein may be the trademarks of their respective owners.